

**flowNPC2 NPC Application 600V/200A**

General conditions

V<sub>out</sub>= 230 VAC

BUCK	
V <sub>GEon</sub>	= 15 V
V <sub>GEoff</sub>	= -15 V
R <sub>gon</sub>	= 4 Ω
R <sub>goff</sub>	= 4 Ω

BOOST	
V <sub>GEon</sub>	= 15 V
V <sub>GEoff</sub>	= -15 V
R <sub>gon</sub>	= 4 Ω
R <sub>goff</sub>	= 4,015 Ω

**Figure 1. Buck MOSFET**  
Typical average static loss as a function of

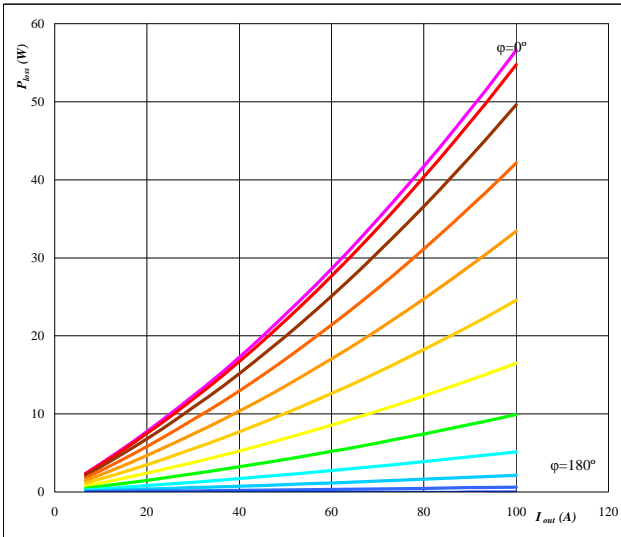

Conditions: T<sub>j</sub>= 150 °C  
parameter: φ from 0° to 180°  
in 12 steps

**Figure 2. Buck FRED**  
Typical average static loss as a function of output current I<sub>oRMS</sub>

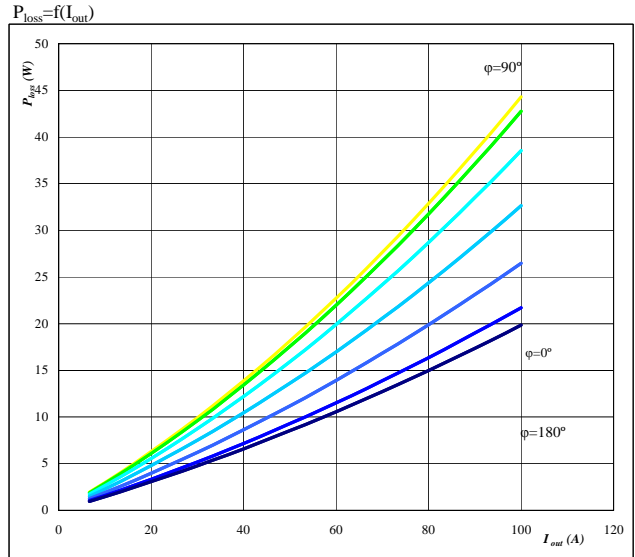

Conditions: T<sub>j</sub>= 150 °C  
parameter: φ from 0° to 180°  
in 12 steps

**Figure 3. Buck MOSFET**  
Typical average static loss as a function of phase displacement φ

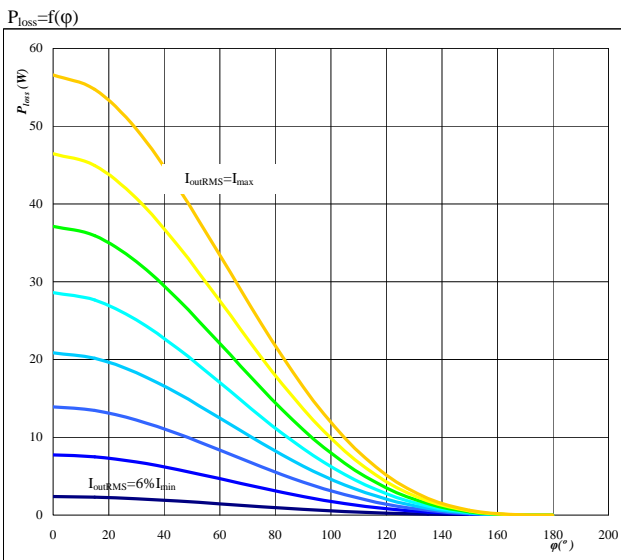

Conditions: T<sub>j</sub>= 150 °C  
parameter: I<sub>oRMS</sub> from 6,67 A to 100 A  
in steps of 13 A

**Figure 4. Buck FRED**  
Typical average static loss as a function of phase displacement φ

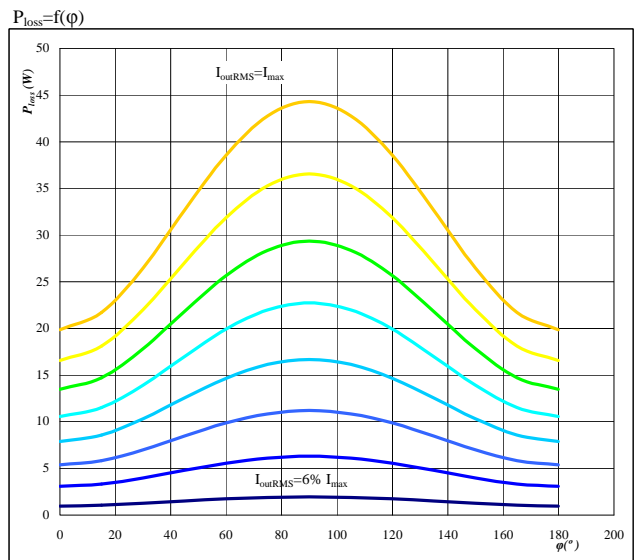

Conditions: T<sub>j</sub>= 150 °C  
parameter: I<sub>oRMS</sub> from 6,67 A to 100 A  
in steps of 13 A

**Figure 5. Buck MOSFET**

**Typical average switching loss as a function of phase displacement  $\phi$**

$P_{loss}=f(\phi)$

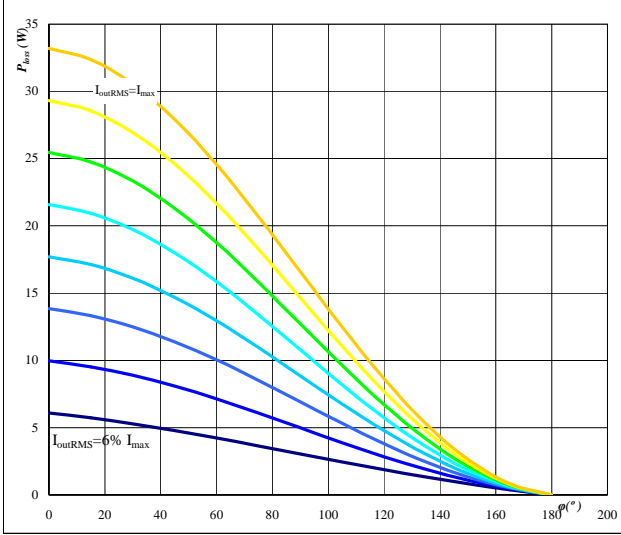

Conditions:  $T_j= 150 \text{ }^\circ\text{C}$   
 $f_{sw}= 20 \text{ kHz}$   
 DC link= 700 V  
 parameter:  $I_{oRMS}$  from 6,67 A to 100 A  
 in steps of 13 A

**Figure 6. Buck FRED**

**Typical average switching loss as a function of phase displacement  $\phi$**

$P_{loss}=f(\phi)$

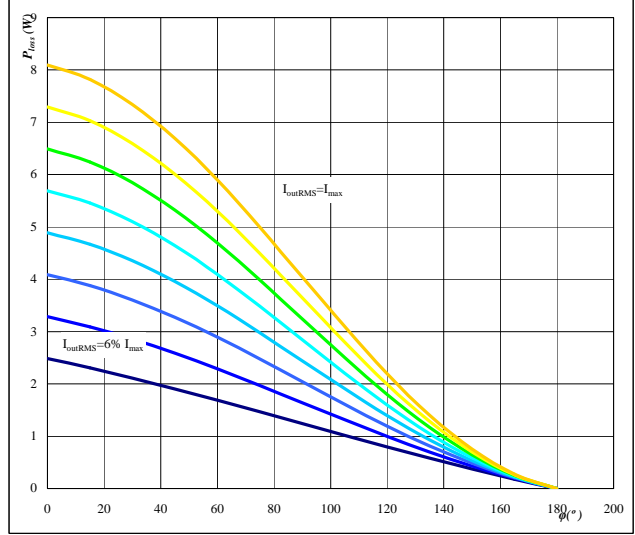

Conditions:  $T_j= 150 \text{ }^\circ\text{C}$   
 $f_{sw}= 20 \text{ kHz}$   
 DC link= 700 V  
 parameter:  $I_{oRMS}$  from 6,67 A to 100 A  
 in steps of 13 A

**Figure 7. Buck MOSFET**

**Typical total loss as a function of phase displacement  $\phi$  and output current  $I_{oRMS}$**

$P_{loss}=f(I_{oRMS};\phi)$

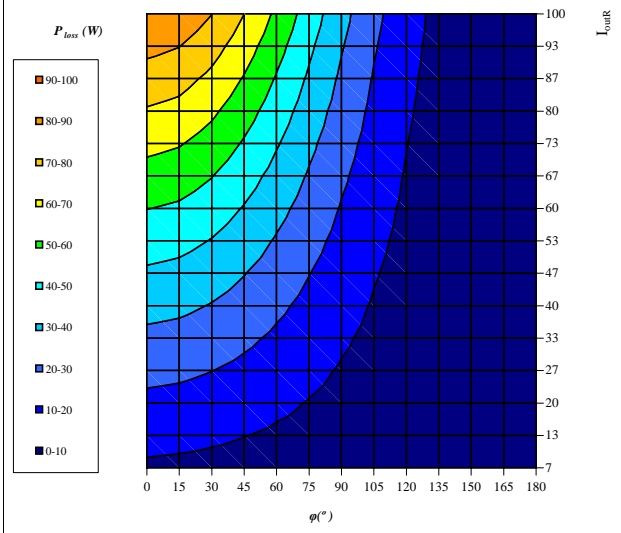

Conditions:  $T_j= 150 \text{ }^\circ\text{C}$   
 DC link= 700 V  
 $f_{sw}= 20 \text{ kHz}$

**Figure 8. Buck FRED**

**Typical total loss as a function of phase displacement  $\phi$  and output current  $I_{oRMS}$**

$P_{loss}=f(I_{oRMS};\phi)$

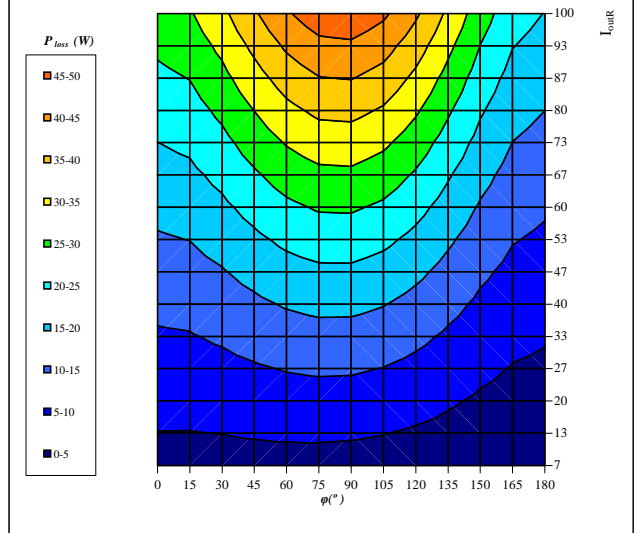

Conditions:  $T_j= 150 \text{ }^\circ\text{C}$   
 DC link= 700 V  
 $f_{sw}= 20 \text{ kHz}$

flowNPC2 **NPC Application** 600V/200A

**Figure 9.** for Buck MOSFET+FRED

**Typical available output current as a function of phase displacement  $\phi$**

$I_{out}=f(\phi)$

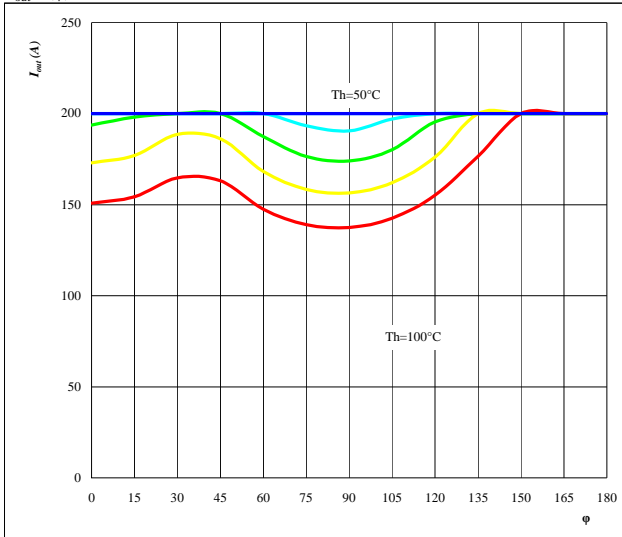

Conditions:  $T_j = T_{jmax}-25 \text{ }^\circ\text{C}$   $f_{sw} = 20 \text{ kHz}$   
 DC link= 700 V  
 parameter: Heatsink temp.  
 $T_h$  from 50  $^\circ\text{C}$  to 100  $^\circ\text{C}$   
 in 10  $^\circ\text{C}$  steps

**Figure 10.** for Buck MOSFET+FRED

**Typical available output current as a function of switching frequency  $f_{sw}$**

$I_{out}=f(f_{sw})$

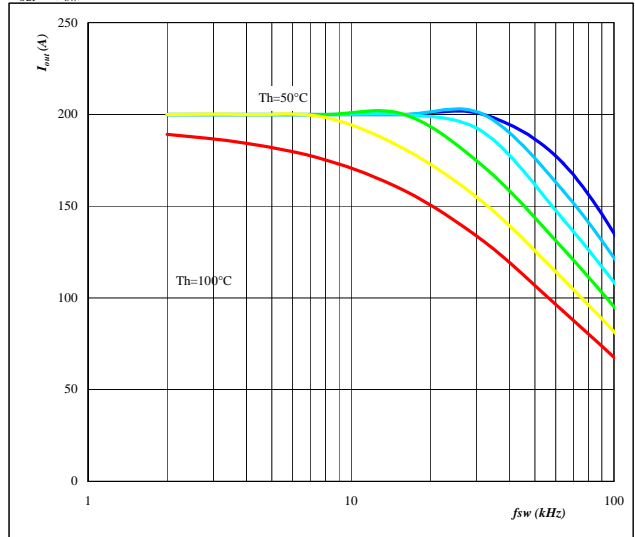

Conditions:  $T_j = T_{jmax}-25 \text{ }^\circ\text{C}$   $\phi = 0^\circ$   
 DC link= 700 V  
 parameter: Heatsink temp.  
 $T_h$  from 50  $^\circ\text{C}$  to 100  $^\circ\text{C}$   
 in 10  $^\circ\text{C}$  steps

**Figure 11.** for Buck IGBT+FRED

**Typical available 50Hz output current as a function of  $f_{sw}$  and phase displacement  $\phi$**

$I_{out}=f(f_{sw},\phi)$

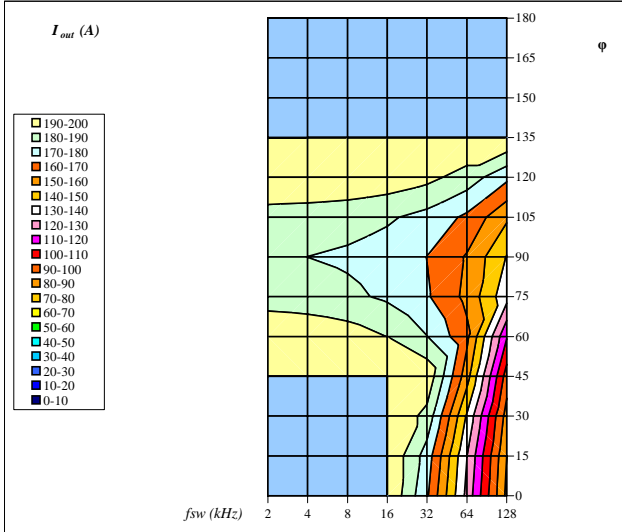

Conditions:  $T_j = T_{jmax}-25 \text{ }^\circ\text{C}$   
 DC link= 700 V  
 $T_h = 80 \text{ }^\circ\text{C}$

flowNPC2 **NPC Application** 600V/200A

**Figure 12.** Boost IGBT

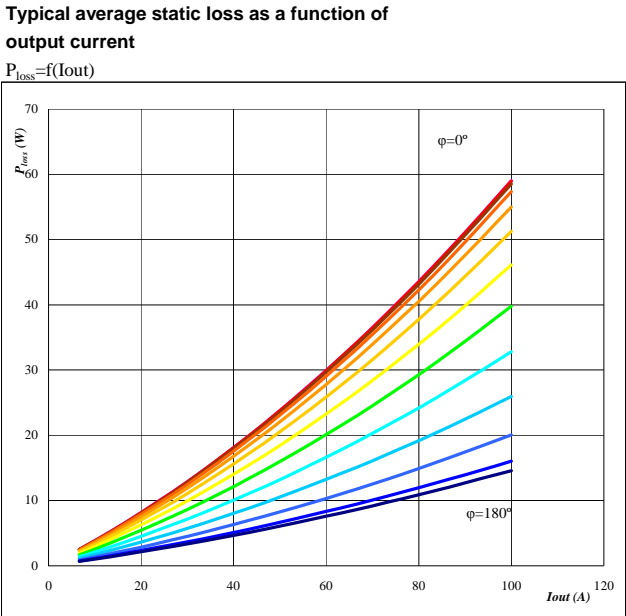

Conditions:  $T_j = 150$  °C  
 parameter:  $\phi$  from 0° to 180°  
 in 12 steps

**Figure 13.** Boost FRED

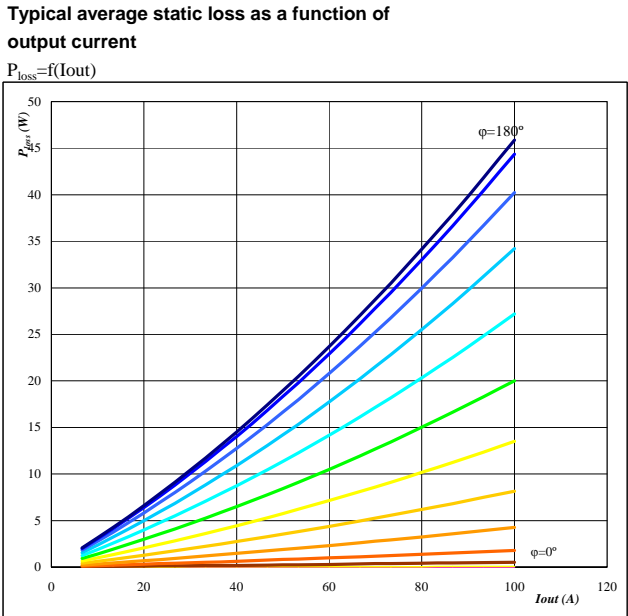

Conditions:  $T_j = 150$  °C  
 parameter:  $\phi$  from 0° to 180°  
 in 12 steps

**Figure 14.** Boost IGBT

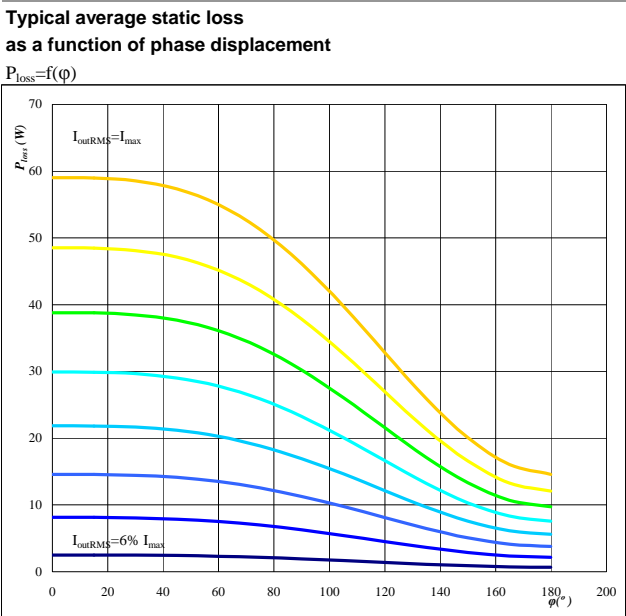

Conditions:  $T_j = 150$  °C  
 parameter:  $I_{oRMS}$  from 7 A to 100 A  
 in steps of 13 A

**Figure 15.** Boost FRED

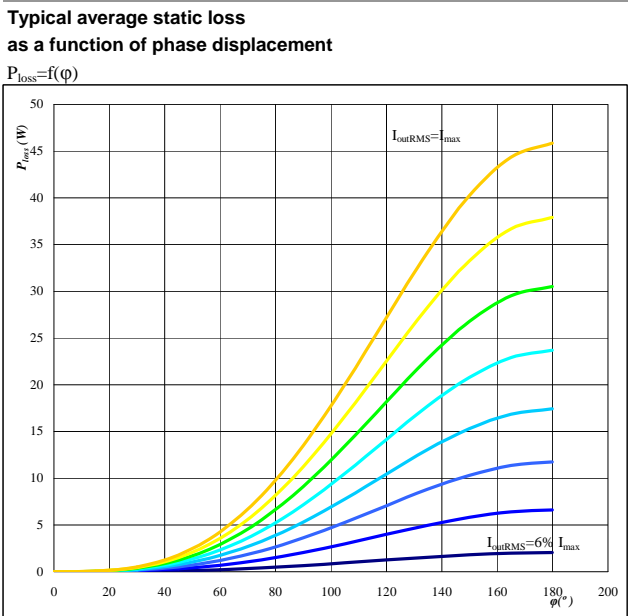

Conditions:  $T_j = 150$  °C  
 parameter:  $I_{oRMS}$  from 7 A to 100 A  
 in steps of 13 A

flowNPC2 **NPC Application** 600V/200A

**Figure 16. Boost IGBT**

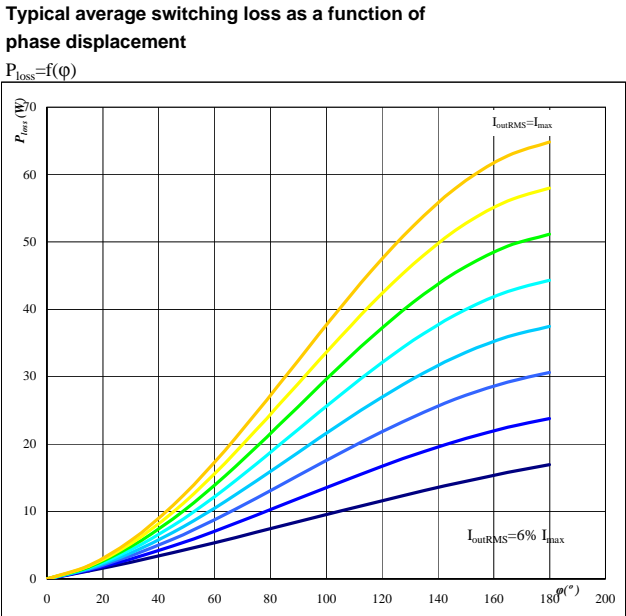

Conditions:  $T_j = 150$  °C  $f_{sw} = 20$  kHz  
 DC link = 700 V  
 parameter:  $I_{oRMS}$  from 7 A to 100 A  
 in steps of 13 A A

**Figure 17. Boost FRED**

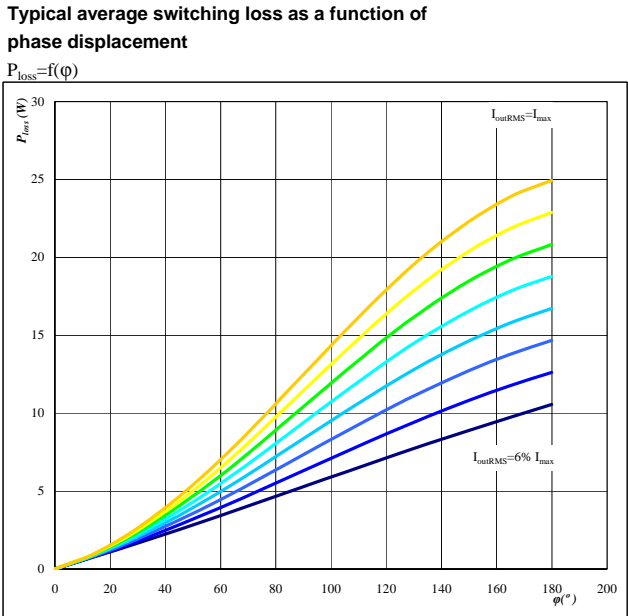

Conditions:  $T_j = 150$  °C  $f_{sw} = 20$  kHz  
 DC link = 700 V  
 parameter:  $I_{oRMS}$  from 7 A to 100 A  
 in steps of 13 A A

**Figure 18. Boost IGBT**

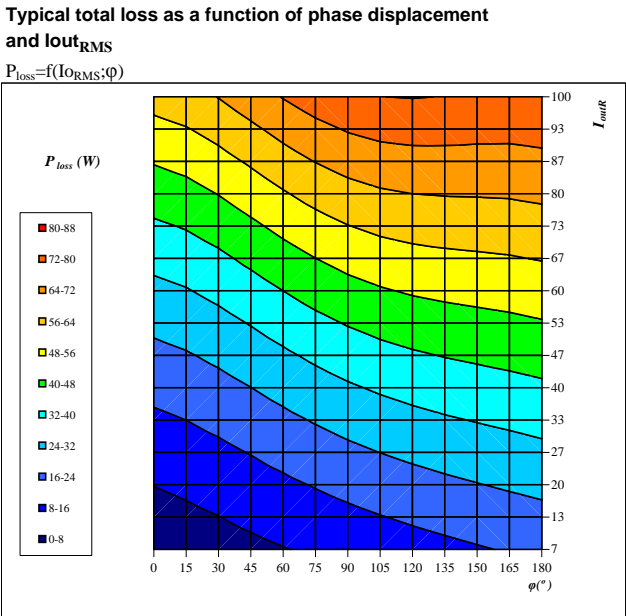

Conditions:  $T_j = 150$  °C  
 DC link = 700 V  
 $f_{sw} = 20$  kHz

**Figure 19. Boost FRED**

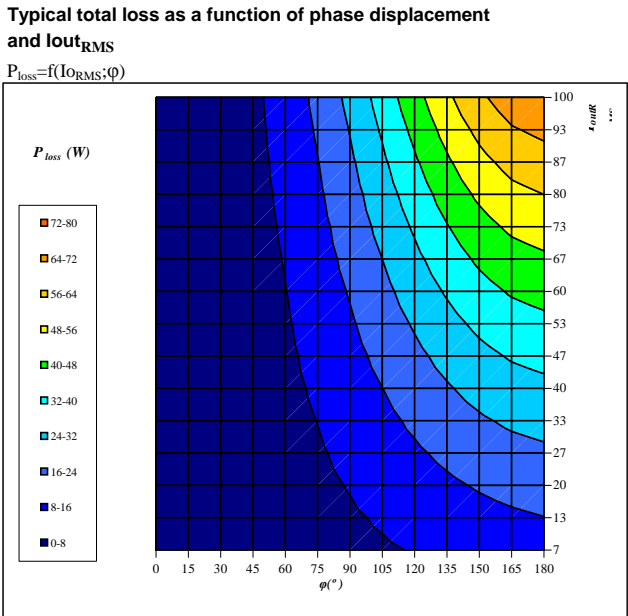

Conditions:  $T_j = 150$  °C  
 DC link = 700 V  
 $f_{sw} = 20$  kHz

**flowNPC2 NPC Application 600V/200A**

**Figure 20. Boost IGBT+FRED**

**Typical available output current as a function of phase displacement**

$I_{out}=f(\varphi)$

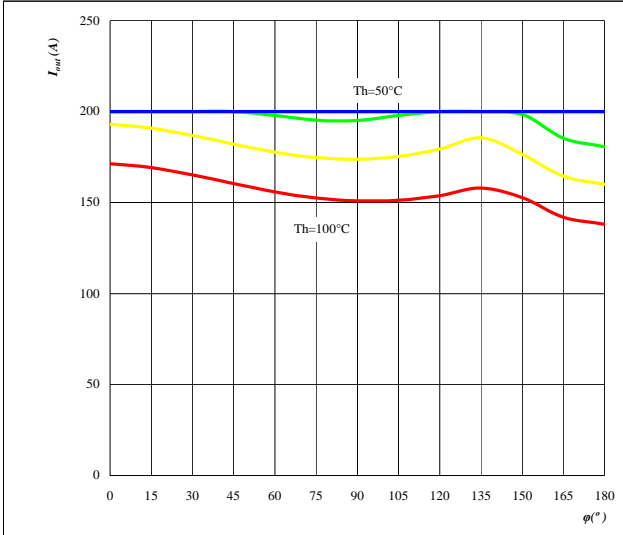

Conditions:  $T_j = T_{jmax} - 25 \text{ }^\circ\text{C}$   $f_{sw} = 20 \text{ kHz}$   
 DC link = 700 V  
 parameter: Heatsink temp.  
 $T_h$  from 50  $^\circ\text{C}$  to 100  $^\circ\text{C}$   
 in 10  $^\circ\text{C}$  steps

**Figure 21. Boost IGBT+FRED**

**Typical available output current as a function of switching frequency**

$I_{out}=f(f_{sw})$

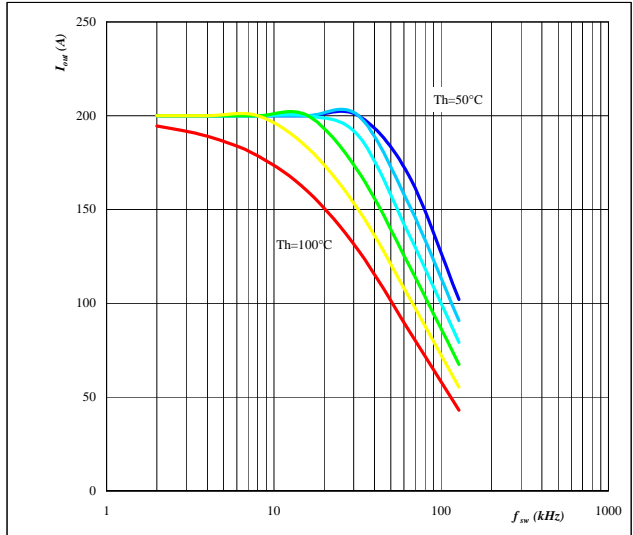

Conditions:  $T_j = T_{jmax} - 25 \text{ }^\circ\text{C}$   $\varphi = 90^\circ$   
 DC link = 700 V  
 parameter: Heatsink temp.  
 $T_h$  from 50  $^\circ\text{C}$  to 100  $^\circ\text{C}$   
 in 10  $^\circ\text{C}$  steps

**Figure 22. Boost IGBT+FRED**

**Typical available 50Hz output current as a function of fsw and phase displacement**

$I_{out}=f(f_{sw}, \varphi)$

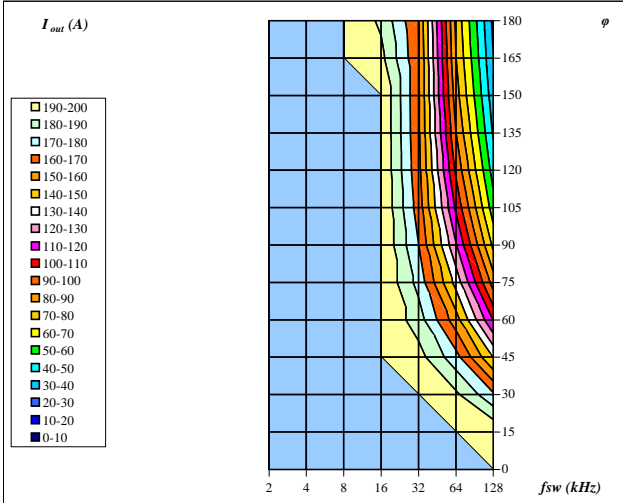

Conditions:  $T_j = T_{jmax} - 25 \text{ }^\circ\text{C}$   
 DC link = 700 V  
 $T_h = 80 \text{ }^\circ\text{C}$

**flowNPC2 NPC Application 600V/200A**

**Figure 23.** per MODULE

**Typical available output current as a function of heat sink temperature**

$$I_{out} = f(T_h)$$

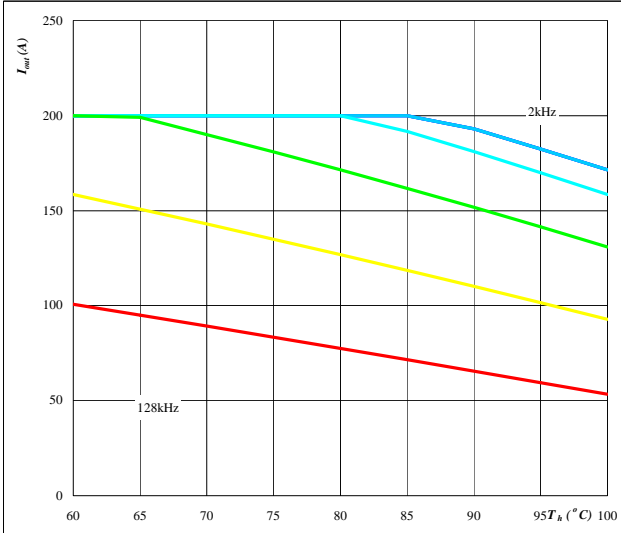

Conditions:  $T_j = T_{jmax} - 25 \text{ } ^\circ\text{C}$   
 DC link = 700 V  
 $\phi = 0^\circ$   
 parameter: Switching freq.  
 fsw from 2 kHz to 128 kHz  
 in steps of factor 2

**Figure 24.** per MODULE

**Typical available output current as a function of phase displacement**

$$I_{out} = f(\phi)$$

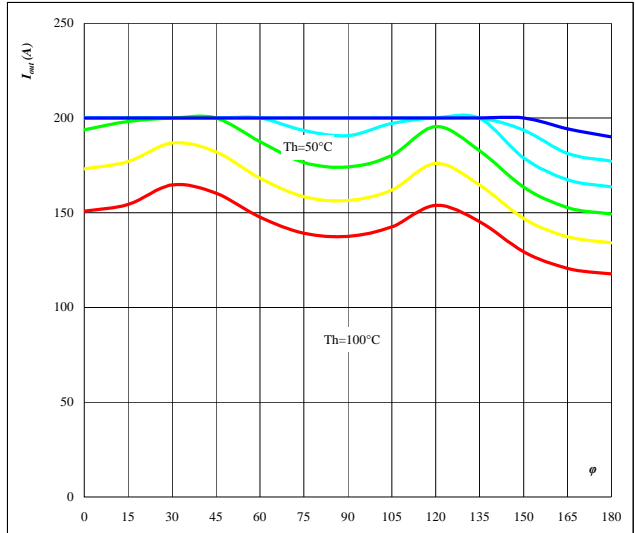

Conditions:  $T_j = T_{jmax} - 25 \text{ } ^\circ\text{C}$   
 DC link = 700 V  
 $f_{sw} = 20 \text{ kHz}$   
 parameter: Heatsink temp.  
 Th from 50 °C to 100 °C  
 in 10 °C steps

**Figure 25.** per MODULE

**Typical available output current as a function of switching frequency**

$$I_{out} = f(f_{sw})$$

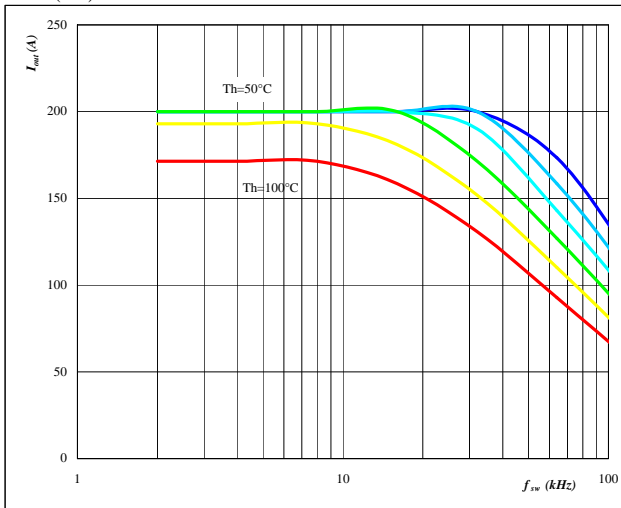

Conditions:  $T_j = T_{jmax} - 25 \text{ } ^\circ\text{C}$   $\phi = 0^\circ$   
 DC link = 700 V  
 parameter: Heatsink temp.  
 Th from 50 °C to 100 °C  
 in 10 °C steps

**Figure 26.** per MODULE

**Typical available 50Hz output current as a function of fsw and phase displacement**

$$I_{out} = f(f_{sw}, \phi)$$

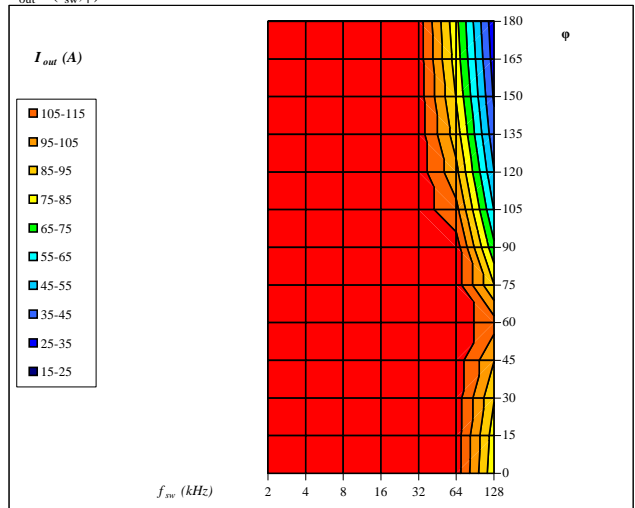

Conditions:  $T_j = T_{jmax} - 25 \text{ } ^\circ\text{C}$   
 DC link = 700 V  
 $T_h = 80 \text{ } ^\circ\text{C}$

**flowNPC2 NPC Application 600V/200A**

**Figure 27.** per MODULE

**Typical efficiency as a function of output power**

$\eta=f(P_{out})$

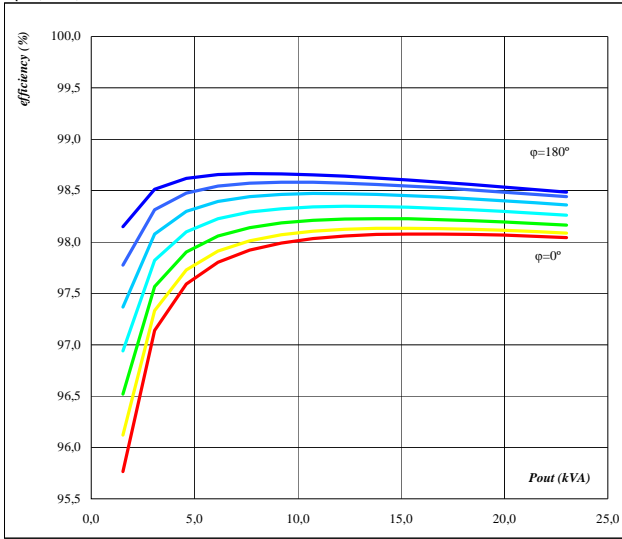

Conditions:  $T_j = 150\text{ }^\circ\text{C}$   
 $f_{sw} = 20\text{ kHz}$   
 DC link = 700 V  
 parameter: phase displacement  $\phi$  from  $0^\circ$  to  $180^\circ$  in steps of  $30^\circ$

**Figure 28.** per MODULE

**Typical efficiency as a function of output power**

$\eta=f(P_{out})$

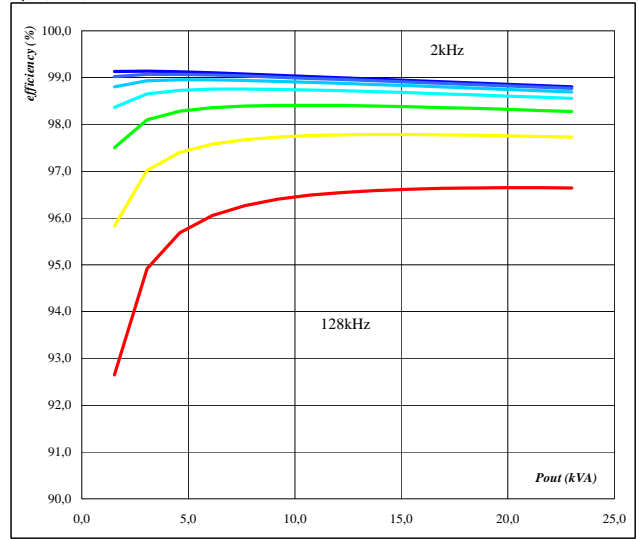

Conditions:  $T_j = 150\text{ }^\circ\text{C}$   $\phi = 0^\circ$   
 DC link = 700 V  
 parameter: Switching freq.  $f_{sw}$  from 2 kHz to 128 kHz in steps of factor 2

**Figure 29.** per MODULE

**Typical available output power as a function of heat sink temperature**

$P_{out}=f(T_h)$

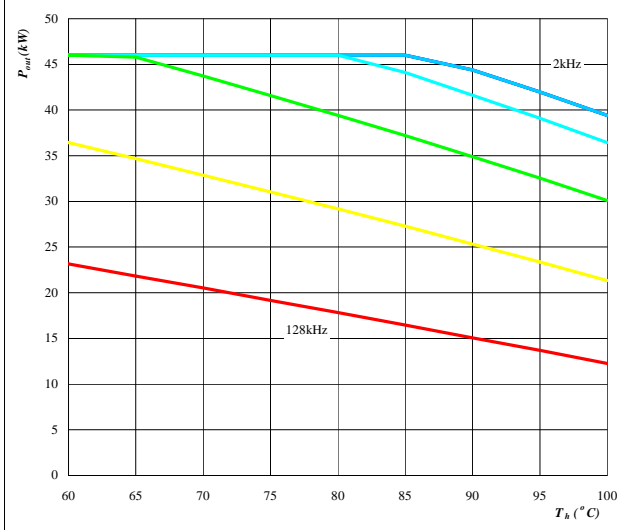

Conditions:  $T_j = T_{jmax}-25\text{ }^\circ\text{C}$   
 DC link = 700 V  
 $\phi = 0^\circ$   
 parameter: Switching freq.  $f_{sw}$  from 2 kHz to 128 kHz in steps of factor 2

**Figure 30.** per MODULE

**Typical loss distribution as a function of output current**

$P_{out}=f(T_h)$

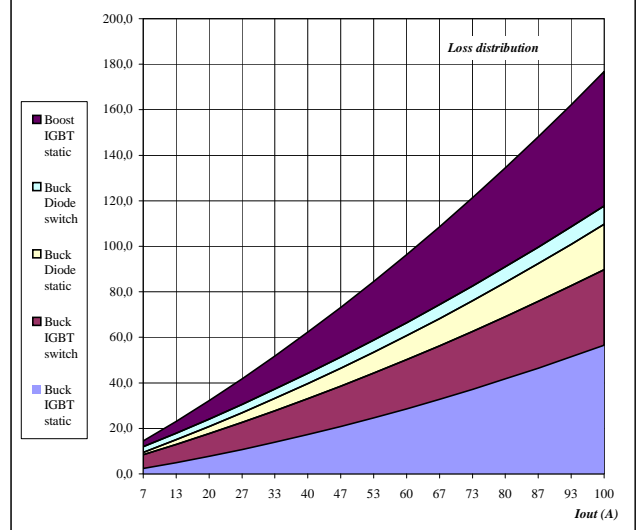

Conditions:  $T_j = 150\text{ }^\circ\text{C}$   
 $f_{sw} = 20\text{ kHz}$   
 DC link = 700 V  
 $\phi = 0^\circ$

flowNPC2 **NPC Application** 600V/200A

Figure 31. **per MODULE**

Typical relative loss distribution as a function of output current

$$P_{out} = f(T_h)$$

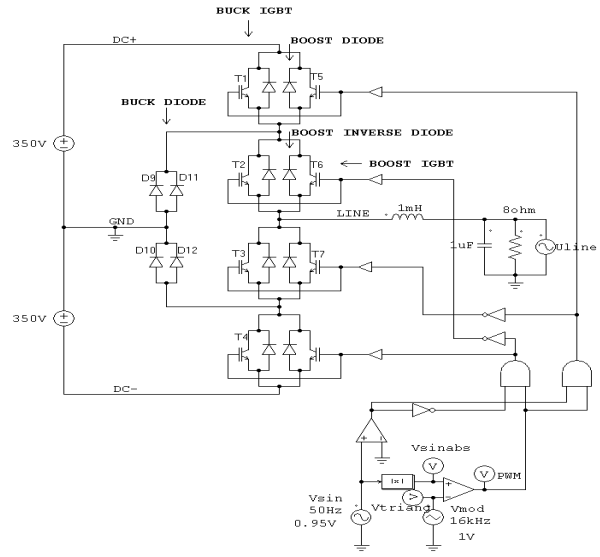
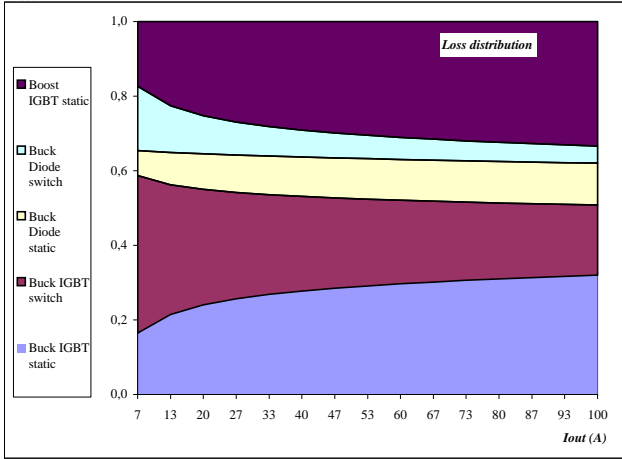

Conditions:  $T_j = 150$  °C  
 $f_{sw} = 20$  kHz  
 DC link = 700 V  
 $\phi = 0^\circ$

**PRODUCT STATUS DEFINITIONS**

Datasheet Status	Product Status	Definition
Target	Formative or In Design	This datasheet contains the design specifications for product development. Specifications may change in any manner without notice. The data contained is exclusively intended for technically trained staff.
Preliminary	First Production	This datasheet contains preliminary data, and supplementary data may be published at a later date. Vincotech reserves the right to make changes at any time without notice in order to improve design. The data contained is exclusively intended for technically trained staff.
Final	Full Production	This datasheet contains final specifications. Vincotech reserves the right to make changes at any time without notice in order to improve design. The data contained is exclusively intended for technically trained staff.

**DISCLAIMER**

The information given in this datasheet describes the type of component and does not represent assured characteristics. For tested values please contact Vincotech. Vincotech reserves the right to make changes without further notice to any products herein to improve reliability, function or design. Vincotech does not assume any liability arising out of the application or use of any product or circuit described herein; neither does it convey any license under its patent rights, nor the rights of others.

**LIFE SUPPORT POLICY**

Vincotech products are not authorised for use as critical components in life support devices or systems without the express written approval of Vincotech.

As used herein:

1. Life support devices or systems are devices or systems which, (a) are intended for surgical implant into the body, or (b) support or sustain life, or (c) whose failure to perform when properly used in accordance with instructions for use provided in labelling can be reasonably expected to result in significant injury to the user.
2. A critical component is any component of a life support device or system whose failure to perform can be reasonably expected to cause the failure of the life support device or system, or to affect its safety or effectiveness.