

LTM4602 20V, 6A Step-Down µModule Regulator

DESCRIPTION

Demonstration circuit DC1084A-A features the LTM[®]4602, the high efficiency, high density step-down µModule[®] regulator. The input voltage range is from 5V to 20V. The output voltage is jumper programmable from 0.6V to 5V, refer to the step-down ratio curve in the LTM4602 data sheet. The rated load current is 6A, while derating is necessary for certain V_{IN} , V_{OUT} and thermal conditions.

The LTM4602 data sheet must be read in conjunction with this demo manual prior to working on or modifying demo circuit DC1084A-A.

Design files for this circuit board are available at <http://www.linear.com/demo>

LT, LT, LTC, LTM, µModule, Linear Technology and the Linear logo are registered trademarks of Linear Technology Corporation. All other trademarks are the property of their respective owners.

PERFORMANCE SUMMARY $(T_A = 25^\circ\text{C})$

PARAMETER	CONDITION	VALUE
Input Voltage Range		4.5V to 20V
Output Voltage V_{OUT}	Jumper Selectable (Open for 0.6V)	1.2V, 1.5V, 1.8V, 2.5V, 3.3V, 5V
Maximum Continuous Output Current	Derating is Necessary for Certain V_{IN} , V_{OUT} and Thermal Conditions	6A DC
Default Operating Frequency		800kHz

BOARD PHOTO

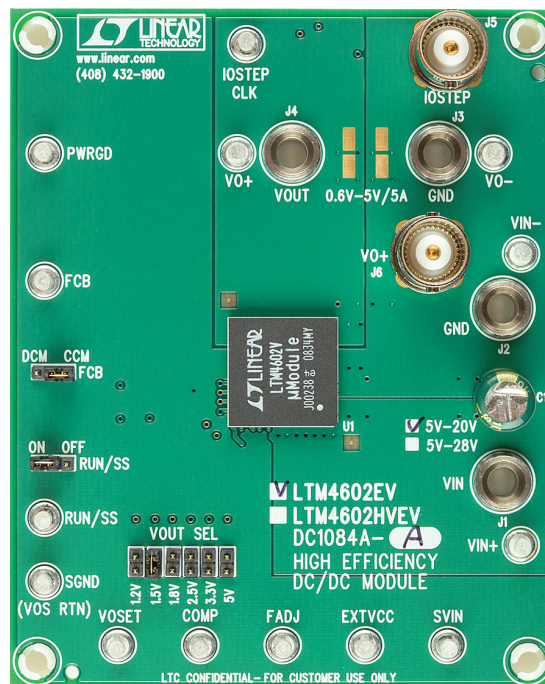

dc1084a-af

DEMO MANUAL DC1084A-A

QUICK START PROCEDURE

Demonstration circuit DC1084A-A is an easy way to evaluate the performance of the LTM4602EV. Please refer to Figure 1 for proper measurement equipment setup and follow the procedure below:

1. Place jumpers in the following positions for a typical 1.5V_{OUT} application:

FCB	RUN/SS	VOUT SEL
CCM	ON	1.5V

2. With power off, preset the load to 0A and V_{IN} supply to be less than 20V. Connect the input power supply, load, optional 5V bias supply and meters as shown in Figure 1. The optional 5V bias supply must be off anytime the supply to V_{IN} is turned off.
3. Turn on the power at the input. The output voltage should be 1.5V ±2%.

4. Once the proper output voltage is established, adjust the load within the operating range and observe the output voltage regulation, ripple voltage, efficiency and other parameters. Output ripple should be measured at J6 with a BNC cable.
5. For optional load transient test, apply adjustable pulse signal between IOSTEP CLK and GND pins. Pulse amplitude sets the current step. The pulse signal should have very small duty cycle (<15%) to limit the thermal stress on the transient load circuit. The output transient current can be monitored at BNC connector J5 (10mV/A).

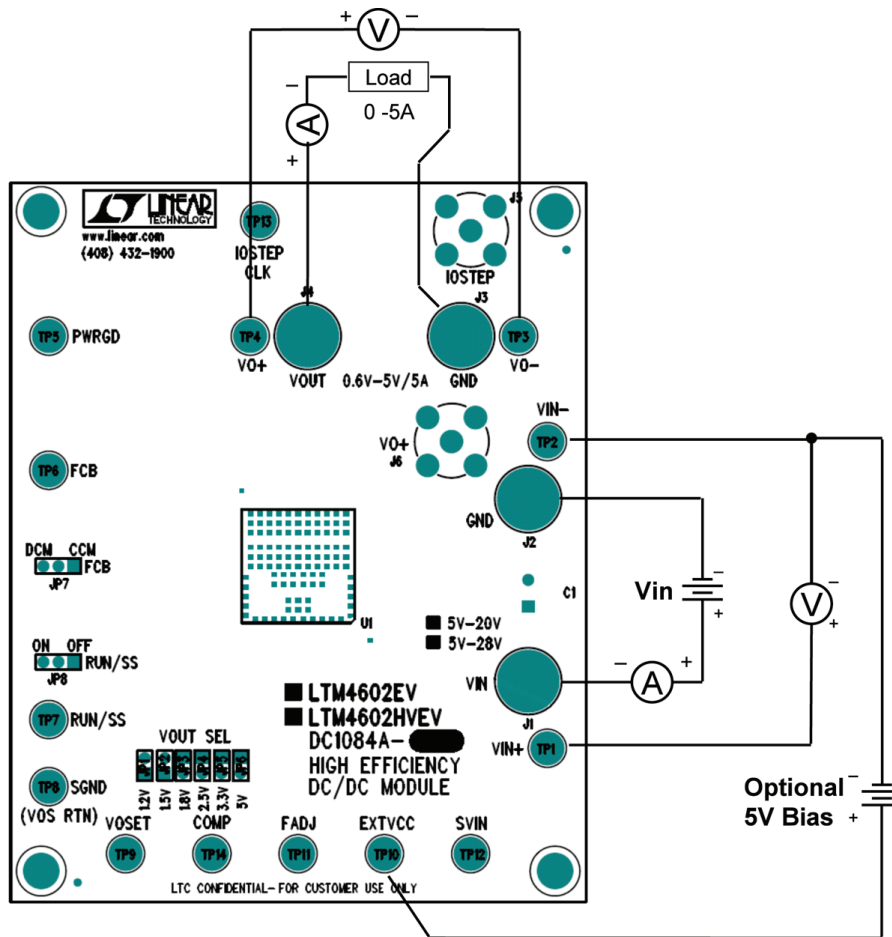

Figure 1. Test Setup of DC1084A-A (EXTV_{CC} Bias Supply is Optional)

dc1084a-af

QUICK START PROCEDURE

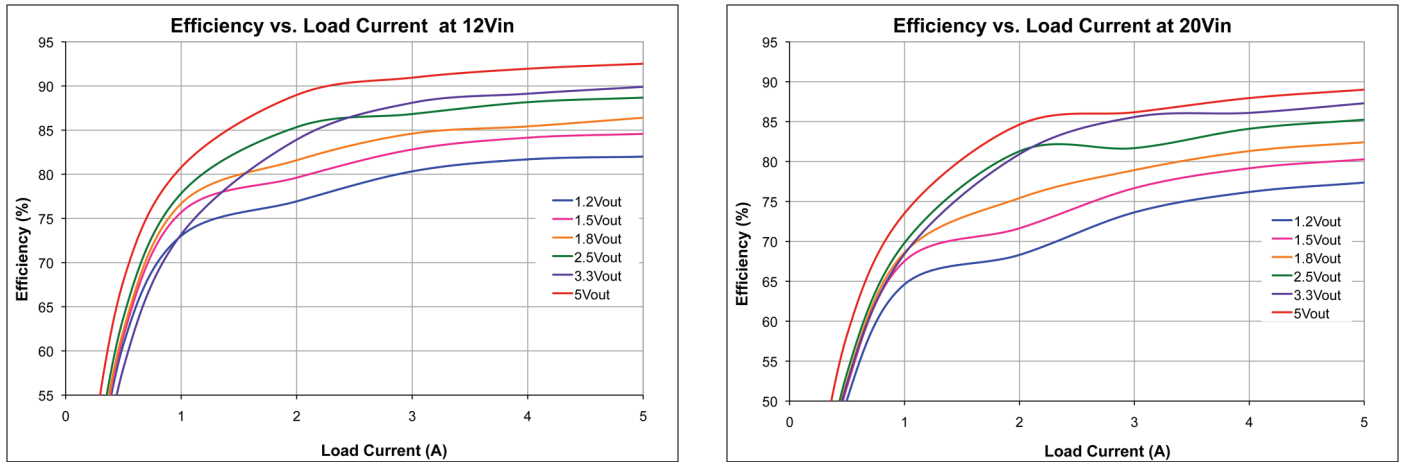
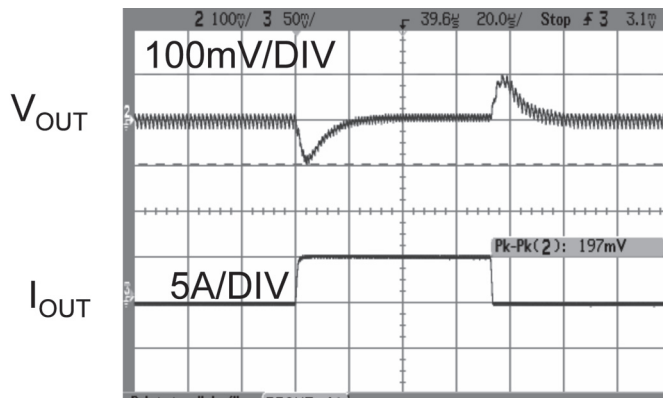

Figure 2. Measured Supply Efficiency with Different V_{IN} and V_{OUT} (FADJ Open: 1.2V_{OUT} to 2.5V_{OUT}, FADJ = 15k Ω : 3.3V_{OUT} to 5V_{OUT})



$V_{IN} = 12V$, $V_{OUT} = 1.5V$
 0A to 5A LOAD STEP
 $FCB = 0V$
 $C_{OUT} = 1 \times 22\mu F$ CERAMIC (1206), $1 \times 100\mu F$ CERAMIC (1812),
 $C3 = 100pF$

Figure 3. Measured Load Transient Response (0A-5A Step)

DEMO MANUAL DC1084A-A

PARTS LIST

ITEM	QTY	REFERENCE	PART DESCRIPTION	MANUFACTURER/PART NUMBER
Required Circuit Components				
1	1	C1	CAP, 150µF 20% 35V ALUM	SANYO 35MV150WXV (Now SUNCON 35MV150WXV)
2	2	C5, C2	CAP, 1206 10µF 20% 35V X5R	TAIYO YUDEN GMK316 BJ106ML-T
3	1	C10	CAP, 1206 22µF 20% 6.3V X5R	AVX 12066D266MAT2A
4	1	C7	CAP, 1812 100µF 20% 6.3V X5R	TDK C4532X5R0J107MZ
5	1	C12	CAP, 0603 100pF 10% 50V X7R	AVX 06035C101KAT1A
6	1	R2	RES, 0603 66.5k 1% 1/10W	AAC CR16-6652FM
7	1	R8	RES, 0603 0Ω JUMPER	ACC CJ06-000M
8	1	U1	IC, LTM4602EV	LINEAR TECH. LTM4602EV
Additional Demo Board Circuit Components				
1	0	C4, C3	CAP, 1206 OPTION	TAIYO YUDEN EMK316BJ475ML-T OPTION
2	0	C8	CAP, 1812 100µF 20% 6.3V X5R OPTION	TDK C4532X5R0J107MZ OPTION
3	0	C6	CAP, 1812 OPTION	TAIYO YUDEN JMK432BJ107MU-T OPTION
4	0	C11, C14, C18, C19	CAP, 0603 OPTION	OPTION
5	1	C13	CAP, 0603 100pF 10% 50V NPO	AVX 06035A101KAT
6	2	C15,C16	CAP, 0603 1µF 20% 10V X5R	TAIYO YUDEN LMK107BJ105MA-T
7	0	C17	CAP, 0805 1µF 20% 16V X5R OPTION	TAIYO YUDEN EMK212BJ105MG-T OPTION
8	1	D1	DIODE, ZENER 4.7V	DIODES INC. BZX84C4V7
9	1	Q14	XSTR, SUD50N03-10CP MOSFET	SILICONIX SUD50N03-10CP
10	1	R1	RES, 0603 49.9k 1% 1/10W	AAC CR16-4992FM
11	1	R3	RES, 0603 31.6k 1% 1/10W	AAC CR16-3162FM
12	1	R4	RES, 0603 22.1k 1% 1/10W	AAC CR16-2212FM
13	1	R5	RES, 0603 13.7k 1% 1/10W	AAC CR16-1372FM
14	3	R6, R10, R12	RES, 0603 10k 5% 1/10W	VISHAY CRCE060310K0JNEA
15	1	R7	RES, 0603 5.1k 5% 1/10W	AAC CR16-512JM
16	1	R9	RES, 0603 1M 5% 1/16W	AAC CR16-105JM
17	1	R11	RES, 2512 0.01Ω 5% 1W	IRC LRF2512-01-R010-J
18	0	R13	RES, 0603 OPTION	OPTION
19	1	R14	RES, 0603 100k 1% 1/10W	AAC CR16-1003FM

SCHEMATIC DIAGRAM

REVISION HISTORY				
ECO	REV	DESCRIPTION	DATE	APPROVED
	1	PROTO	03/27/06	

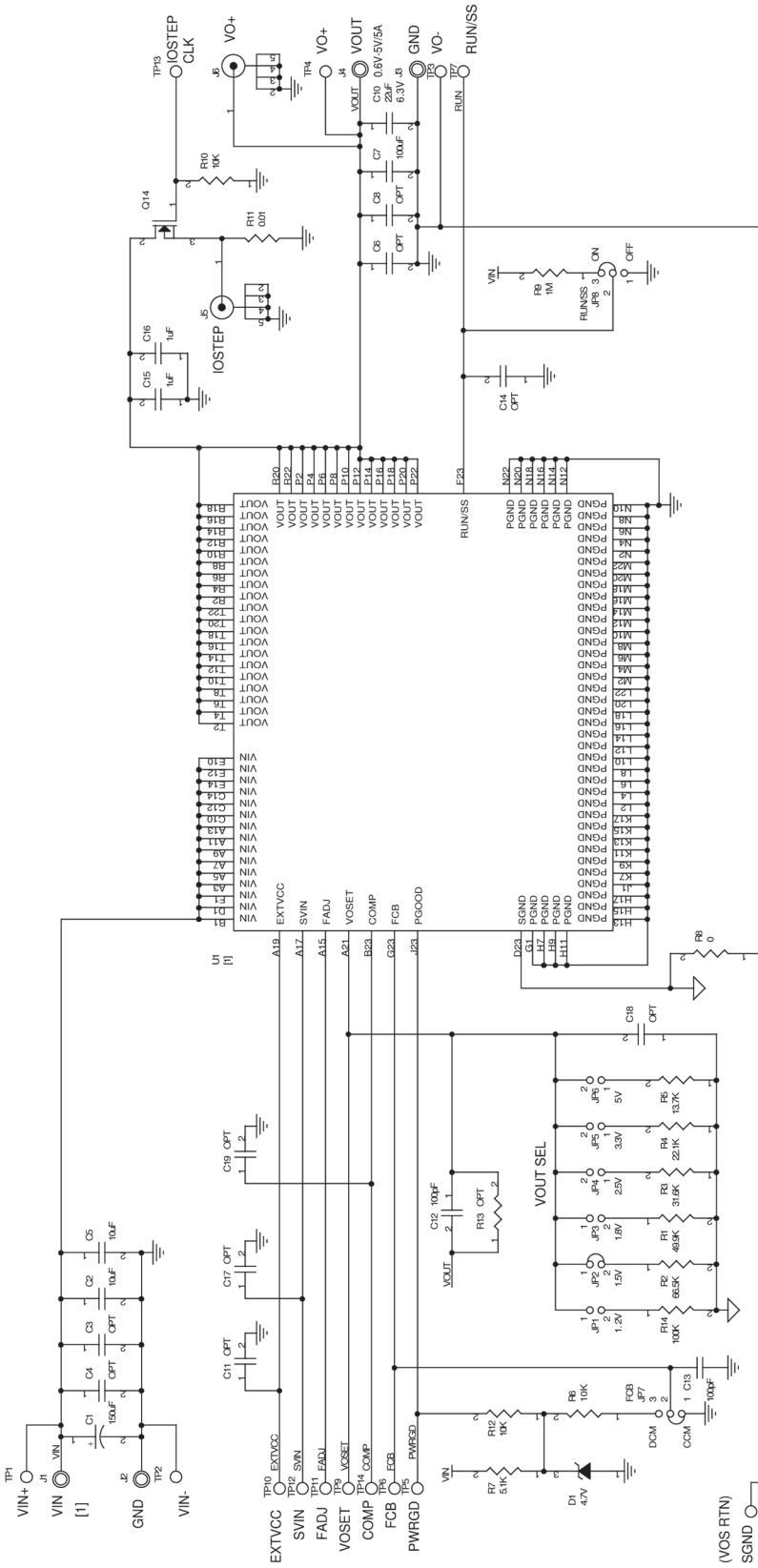

This circuit is proprietary to Linear Technology and supplied for use with Linear Technology parts.
Customer Notice: Linear Technology has made a best effort to design a circuit that meets customer-supplied specifications; however, we do not warrant the reliability of the circuit for any application and reliable operation in the actual application. Component substitution and printed circuit board layout may significantly affect circuit performance or reliability. Contact Linear Applications Engineering for assistance.

JUMPER	VOUT
JP1	1.2V
JP2	1.5V
JP3	1.8V
JP4	2.5V
JP5	3.3V
JP6	5V

VERSION	VIN	MODULE
-A	5V-20V	LTM4602EV
-B	5V-28V	LTM4602HVEV

LINEAR TECHNOLOGY

1800 McCarty Rd
 Milpitas, CA 95035
 Phone: (408) 521-1800
 Fax: (408) 521-0207

CONTRACT NO. _____
DATE 08/04/04
APPROVALS _____
 DRAWN: MEI
 CHECKED _____
 APPROVED _____
 ENGINEER _____
 DESIGNER _____

TITLE SCH1, LTM4602EV/HVEV HIGH EFFICIENCY DC/DC MODULE

SCALE: NONE
FILENAME: 1084A-1.DSN
FILENAME: DC1084A
REV 1
REV 1
OF 1

UNLESS OTHERWISE SPECIFIED
 DIMENSIONS ARE IN INCHES
 DIMENSIONS IN PARENTHESES ARE IN MILLIMETERS
 2 PLACES - . . . 3 PLACES - . . .
 INTERPRET DIM AND TOL.
 PER ASME Y14.5M - 1994

THIRD ANGLE PROJECTION

DO NOT SCALE DRAWING

Monday, October 23, 2006

DEMO MANUAL DC1084A-A

DEMONSTRATION BOARD IMPORTANT NOTICE

Linear Technology Corporation (LTC) provides the enclosed product(s) under the following **AS IS** conditions:

This demonstration board (DEMO BOARD) kit being sold or provided by Linear Technology is intended for use for **ENGINEERING DEVELOPMENT OR EVALUATION PURPOSES ONLY** and is not provided by LTC for commercial use. As such, the DEMO BOARD herein may not be complete in terms of required design-, marketing-, and/or manufacturing-related protective considerations, including but not limited to product safety measures typically found in finished commercial goods. As a prototype, this product does not fall within the scope of the European Union directive on electromagnetic compatibility and therefore may or may not meet the technical requirements of the directive, or other regulations.

If this evaluation kit does not meet the specifications recited in the DEMO BOARD manual the kit may be returned within 30 days from the date of delivery for a full refund. **THE FOREGOING WARRANTY IS THE EXCLUSIVE WARRANTY MADE BY THE SELLER TO BUYER AND IS IN LIEU OF ALL OTHER WARRANTIES, EXPRESSED, IMPLIED, OR STATUTORY, INCLUDING ANY WARRANTY OF MERCHANTABILITY OR FITNESS FOR ANY PARTICULAR PURPOSE. EXCEPT TO THE EXTENT OF THIS INDEMNITY, NEITHER PARTY SHALL BE LIABLE TO THE OTHER FOR ANY INDIRECT, SPECIAL, INCIDENTAL, OR CONSEQUENTIAL DAMAGES.**

The user assumes all responsibility and liability for proper and safe handling of the goods. Further, the user releases LTC from all claims arising from the handling or use of the goods. Due to the open construction of the product, it is the user's responsibility to take any and all appropriate precautions with regard to electrostatic discharge. Also be aware that the products herein may not be regulatory compliant or agency certified (FCC, UL, CE, etc.).

No License is granted under any patent right or other intellectual property whatsoever. **LTC assumes no liability for applications assistance, customer product design, software performance, or infringement of patents or any other intellectual property rights of any kind.**

LTC currently services a variety of customers for products around the world, and therefore this transaction **is not exclusive**.

Please read the DEMO BOARD manual prior to handling the product. Persons handling this product must have electronics training and observe good laboratory practice standards. **Common sense is encouraged.**

This notice contains important safety information about temperatures and voltages. For further safety concerns, please contact a LTC application engineer.

Mailing Address:

Linear Technology
1630 McCarthy Blvd.
Milpitas, CA 95035

Copyright © 2004, Linear Technology Corporation