



Size: 4.60in x 3.2in x 0.55in
(116.8mm x 82mm x 18mm)

FEATURES

- Wide Input Range
- Industry Standard Full Brick Package
- High Reliability
- High Efficiency
- High Power Density
- Low Ripple and Noise
- Over Current, Over Voltage, Over Temperature, and Short Circuit Protection
- Input Under & Over Voltage Protection
- RoHS5 Compliant
- UL/IEC/EN60950/GB4943 Compliant

APPLICATIONS

- Radar
- Defense
- Industrial Control
- High Reliability Electronic Equipment

DESCRIPTION

The DCHPW1500 series of DC/DC converters offers up to 1500 watts of output power in a 4.60" x 3.2" x 0.55" full brick package. This series consists of single output models with a wide input range as well as high reliability, efficiency and power density. This series also has protection against over current, over voltage, over temperature, short circuit, and input under and over voltage conditions. The DCHPW1500 series is RoHS5 and UL/IEC/EN60950/GB4943 compliant.

MODEL SELECTION TABLE

Model Number	Input Voltage Range	Output Voltage	Output Current	Ripple & Noise	Output Power	Efficiency
DCHPW1500-450S28	200~750VDC	28VDC	54A	150mV	1500W	94.5%
DCHPW1500-450S48*		48VDC	31A	200mV	1500W	95%

*Preliminary

SPECIFICATIONS

All specifications are based on 25°C Case Temperature, Nominal Input Voltage, Nominal Output Voltage, and Full Load unless otherwise noted. We reserve the right to change specifications based on technological advances.

SPECIFICATION	TEST CONDITIONS	Min	Typ	Max	Unit	
INPUT SPECIFICATIONS						
Input Voltage Range		200	450	750	VDC	
Operating Voltage	Absolute Maximum Rating, Continuous			750	VDC	
Max. Input Current	Vin=200VDC, Po=1200W			7.0	A	
No Load Input Current	Vin=450VDC, Vout=28VDC, Io=0A		65	85	mA	
Non-Operating Input	Absolute Maximum Rating, Continuous	-0.3		800	VDC	
Inrush Transient (I ² t) ⁽¹⁾	Vin=450VDC			5	A ² s	
Input Reflected Ripple Current	Vin=450, Vout=28VDC, Io=54A (See Fig. 3)		400	600	mA	
External Input Capacitor	Low ESR electrolytic capacitor with voltage ≥900VDC ⁽²⁾	47	100		µF	
Input Fuse	Fast Blow Fuse-Link			15	A	
Under Voltage Lockout	DCHPW1500-450S28: Io=27A DCHPW1500-450S48: Io=15.5A	Turn-On	170	180	190	VDC
		Turn-Off	180	190	200	
		Hysteresis		10		
Over Voltage Lockout	DCHPW1500-450S28: Io=27A DCHPW1500-450S48: Io=15.5A	Turn-On	760	770	780	VDC
		Turn-Off	750	760	770	
		Hysteresis		10		
OUTPUT SPECIFICATIONS						
Nominal Output Voltage	DCHPW1500-450S28: Vin=450VDC, Io=27A	27.72	28	28.28	VDC	
	DCHPW1500-450S48: Vin=450VDC, Io=15.5A	47.52	48	48.48		
Nominal Output Voltage Range	DCHPW1500-450S28: Vin=200≤Vin≤650VDC, Io=0-54A; 650≤Vin≤750VDC, Io=8-54A (only)	27.16	28	28.84	VDC	
	DCHPW1500-450S48: Vin=200≤Vin≤650VDC, Io=0-31A; 650≤Vin≤750VDC, Io=6-31A (only)	46.56	48	49.44		
Auxiliary Output Voltage	Output Current: 0-20mA	10.0	11.5	13.0	VDC	
Voltage Accuracy	DCHPW1500-450S28: Vin=200≤Vin≤650VDC, Io=0-54A; 650≤Vin≤750VDC, Io=8-54A (only)			±1	%	
	DCHPW1500-450S48: Vin=200≤Vin≤650VDC, Io=0-31A; 650≤Vin≤750VDC, Io=6-31A (only)					
Accuracy (Ii/Ie-ΣI/nIe)	DCHPW1500-450S28: Vout=28VDC, Io=27-54A		±5	±10	%	
	DCHPW1500-450S48: Vout=48VDC, Io=15.5-31A					
Line Voltage Regulation	DCHPW1500-450S28: 200≤Vin≤380VDC, Io=43A; 380≤Vin≤750VDC, Io=54A			±0.20	%	
	DCHPW1500-450S48: 200≤Vin≤380VDC, Io=25A; 380≤Vin≤750VDC, Io=31A					

SPECIFICATIONS

All specifications are based on 25°C Case Temperature, Nominal Input Voltage, Nominal Output Voltage, and Full Load unless otherwise noted. We reserve the right to change specifications based on technological advances.

SPECIFICATION	TEST CONDITIONS	Min	Typ	Max	Unit	
OUTPUT SPECIFICATIONS (Cont.)						
Load Regulation	DCHPW1500-450S28: Vin=450VDC, Io=0-54A DCHPW1500-450S48: Vin=450VDC, Io=0-31A			±0.50	%	
Voltage Trim	See Application Notes for Voltage Trim	-10		+10	%	
Output Power	See Application Notes for Derating Curve and Voltage Trim	0		1500	W	
Output Current Range	See Application Notes for Derating Curve and Voltage Trim	0		54	A	
Auxiliary Output Current	DCHPW1500-450S28 DCHPW1500-450S48	0		31	A	
Ishare Voltage Reference	DCHPW1500-450S28: Vout=28VDC, Io=54A DCHPW1500-450S48: Vout=48VDC, Io=31A	4.75	5.00	5.25	VDC	
Output External Capacitor	See Application Notes for Typical Application Circuit	3000	4000		µF	
Output Capacitive Load	Resistive (CR) mode	2000	3000		µF	
Ripple & Noise (p-p)	DCHPW1500-450S28: Vin=650≤Vin≤750VDC, Load 8A-54A DCHPW1500-450S48: Vin=650≤Vin≤750VDC, Load 6A-31A		150	280	mV	
Output Voltage Rise Time	10%Vo_set to 90%Vo_set, Full Load		7.5	15	ms	
Start-Up Delay ⁽³⁾	DCHPW1500-450S28 DCHPW1500-450S48		10	20	ms	
Output Voltage Overshoot during Turn On/Off			500	2000	ms	
Transient Response ⁽⁴⁾	DCHPW1500-450S28		1000	1500	mV	
			2000	4000	µs	
	DCHPW1500-450S48		1500	2400	mV	
			2000	4000	µs	
Temperature Coefficient	Tc=-40~+100°C			±0.02	%/°C	
REMOTE ON/OFF CONTROL						
Logic High	Logic High, Module Off	2.4		18.0	VDC	
Logic Low	Open Circuit or Low Logic, Module On	-1.0		0.8	VDC	
Current				6	mA	
ON/OFF (+) to ON/OFF (-)	Absolute Maximum Rating, Continuous (Ripple & Noise <100mVpp)	-2		18	VDC	
Remote Turn On Output Voltage Rising Time ⁽⁵⁾	DCHPW1500-450S28 DCHPW1500-450S48		7.5	15	mS	
Remote Turn-On Start-Up Delay ⁽⁶⁾			10	20	mS	
			40	80	mS	
PROTECTION						
Short Circuit Protection	When output short circuits and output voltage is over the pre-set value (around 20V, 25V maximum for DCHPW1500-450S28 and 35V, 43V for DCHPW1500-450S48), the module will enter protection mode with constant output current. If output voltage is over the pre-set value (around 20V, 25V maximum for DCHPW1500-450S28 and 35V, 43V for DCHPW1500-450S48), the output will be in hiccup mode. It will restart automatically when fault is removed.					
Over Current Protection	Over Current Mode: Current limit → Hiccup → Automatic Recovery	DCHPW1500-450S28: Vin=450VDC, Vout=28VDC	34	36	38	A
		DCHPW1500-450S48: Vin=450VDC, Vout=48VDC	59	62	65	
Over Voltage Protection	Enters a latch mode, input reset to restart	Vin=450VDC, Io=27A	34	35	36	VDC
		Vin=450VDC, Io=15.5A	57	59	61	
Over Temperature Shutdown	Baseplate temperature around the thermistor	Set Point	92	97	102	°C
		Restart	82	87	92	
		Hysteresis		10		
ENVIRONMENTAL SPECIFICATIONS						
Operating Temperature	Case Temperature	-40		+100	°C	
	Case Temperature, Absolute Maximum	-40		+90	°C	
Storage Temperature	Ambient Temperature, Absolute Maximum	-55		+125	°C	
Humidity	Non-Condensing	5		95	%	
Storage Humidity	Non-Condensing	5		95	%	
Pin Solder Temp.	Wave Soldering, Less than 10S			260	°C	
	Wave Soldering, Less than 10S			425	°C	
MTBF	Vin=500VDC, Full Load, Tc=25°C	2x10 ⁶			H	

SPECIFICATIONS

All specifications are based on 25°C Case Temperature, Nominal Input Voltage, Nominal Output Voltage, and Full Load unless otherwise noted.
We reserve the right to change specifications based on technological advances.

SPECIFICATION	TEST CONDITIONS		Min	Typ	Max	Unit
GENERAL SPECIFICATIONS						
Efficiency	DCHPW1500-450S28: Vin=450VDC, Vout=28VDC, Tc=25°C	100% Load	93	94.5		%
		50% Load	92	93		
	DCHPW1500-450S48: Vin=450VDC, Vout=48VDC, Tc=25°C	100% Load	93.5	95		
		50% Load	92	93.5		
Switching Frequency				340		KHz
Electrical Insulation	Test Condition: 10mA/60s No Breakdown, No Arc Over	Input to Output		4250		VDC
		Input to Case		3535		
		Output to Case		1500		
Isolation Resistance	Humidity 90%, Standard Atmospheric Pressure, 500VDC Voltage			≥100		MΩ
PHYSICAL SPECIFICATIONS						
Weight	DCHPW1500-450S28		13.65oz (387g)			
	DCHPW1500-450S48		13.76oz (390g) (estimate)			
Dimensions (L x W x H)			4.60in x 3.2in x 0.55in (116.8mm x 82mm x 18mm)			
Thermal Management			Heatsink or Convection Cooling			
SAFETY CHARACTERISTICS						
Safety Approvals			UL ⁽⁹⁾ /IEC/EN60950/GB4943			
EMC Characteristics	Test together with the end system as a whole	EMI Conducted Noise	GJB151A-97			
		EMS Peak Voltage	GJB151A-97			
RoHS			RoHS5	RoHS compliant materials + lead soldering		
Max. Surge Voltage	Absolute Maximum Rating, ≤1s				800	VDC
Standards and Specifications			MIL-STD-810F	Environmental engineering considerations and laboratory tests		
			MIL-STD-461E	Requirement for the control of electromagnetic interference characteristics of subsystems and equipment		
			MIL-STD-202	Test methods for electronic and electrical component parts		
			MIL-HDBK-217F	Reliability prediction of electronic equipment		
			MIL-M-28787	Modules, standard electronic general specification		

NOTES

- With external 22uF fast transient response, Low ESR electrolytic capacitor, 12uH Inductance.
- If temperature is <-25°C, need to add 2.2uG/1000V CBB.
- Input voltage rising up to the under voltage lockout restart voltage and measure the time V_{in_min} to $10\%V_{o_set}$.
- 25%-50%-25%, 50%-75%-50% Step Change Load, di/dt=2.5A/us, output connects a 2000uF solid or polymer capacitor.
- Power at input and then use ON/OFF pin to turn on the module. Measure output voltage rising time $10\%V_{o_set}$ to $90\%V_{o_set}$.
- Power at input and then use ON/OFF pin to turn on the module. Measure output voltage rising time $10\%V_{o_set}$.
- Note: Peak voltage judging method:
 -Based on captioned configurations and test according to the Standard/Class requirements, if no problem found, test result is considered PASS.
 -Based on captioned configurations and test according to the Standard/Class requirements, if no output from the modules because the over voltage protection of the under voltage lockout is triggered or the module failed due to component damaged, the test result is considered FAIL.
 -Based on captioned configurations and test according to the Standard/Class requirements, if there is temporary output voltage fluctuation but not exceeding the voltage regulation limit, output resumes normally after stop testing and no component damage, the test result is considered PASS.
 -Based on captioned configurations and test according to the Standard/Class requirements. If there is temporary output voltage fluctuations with spikes or valleys exceeding the voltage regulation limit, the test result cannot be determined. It will require further product evaluations.
- Modules are designed to operate in parallel with 10pcs or more.
- This product is Listed to applicable standards and requirements by UL.

*Due to advances in technology, specifications subject to change without notice.

ENVIRONMENTAL TESTS

PARAMETER		CONDITIONS	TEST METHOD
High Temp. Test	Storage	125°C, 24H	MIL-STD-810 High Temperature
	Operation	65°C, 24H; 200V, 450V, 750V, each 8h	
Low Temp. Test	Storage	-55°C, 24H	MIL-STD-810 Low Temperature
	Operation	-40°C, 24H, 200V, 450V, 750V, each 8h	
Temp. Shock Test	Storage	-55°C~125°C; Hold Time: 30min; Cycle: 25 times; switching time less than 1min	MIL-STD-810 Temperature Shock, Program I
	Operation	-40°C~65°C; Hold Time: 30min; Cycle: 25 times; switching time less than 1 min	
High Temp. Life Test		Input Nominal, High Temp, 1000h	MIL-STD-202 Life (at elevated ambient temperature)
Static Temperature and Humidity Test		40°C, 95%, 96h	MIL-STD-202 Humidity (steady state)
Interchanging Temperature Humidity Test		25°C~65; 95%; 24H/Cycle, Cycle: 10 times	MIL-STD-202 Moisture Resistance
Salt Fog Test		NaCl: 5±1%; PH: 6.5~7.2 (35±2°C); 96h	MIL-STD-202 Salt Spray, Test Conditions A
Fungus Test		Under the provisions of MIL-STD-810 mold environment, module appearance impact assessment was no more than level 2 after 28d	Meet MIL-STD-810 conditions
Low Pressure Test		58.53kPa, 16h	MIL-STD-202 Barometric Pressure (reduced) Test Conditions F
Vibration (Sinusoidal)		10-55Hz, 0.75mm, 2H/each axis	MIL-STD-202 Vibration
Random Vibration		50-2000Hz, (2 m/s ²) ² /Hz; 50-100Hz, +6dB/OTC; 1000-2000Hz, -6dB/OTC; 30min/each axis	MIL-STD-202 Random Vibration, Test conditions I-A
Shock Test		500m/s ² , 11ms; 3 Perpendicular axis, 6 directions, 3 shocks each axis	MIL-STD-202 Shock (specified pulse); Test Conditions A

RELIABILITY DATA

PARAMETER	STANDARD STAGE	SAMPLE STAGE	CAUSE
A. High Accelerated Life Test (HALT)			
High Temp. Step Stress	√	/	<input type="checkbox"/> Prototypes for new product series <input checked="" type="checkbox"/> Products need high reliability <input checked="" type="checkbox"/> Products working in harsh environment <input type="checkbox"/> Requested by customers
Low Temp. Step Stress	√	/	
Rapid Thermal Cycling Test	/	/	
Vibration Step Stress	√	/	
Comprehensive Stress	√	/	
Operating Temp. Stress	√	/	
B. Quantitative Reliability Test			
Quantitative Reliability Test	/	√	<input type="checkbox"/> Prototypes for new product series <input checked="" type="checkbox"/> Products need high reliability <input checked="" type="checkbox"/> Products need quantitative MTBF estimation <input type="checkbox"/> Requested by customers
C. Endurance Test			
Temp. Shock Test	/	√	<input type="checkbox"/> Prototypes for new product series <input checked="" type="checkbox"/> Products need high reliability <input type="checkbox"/> Products working in harsh environments <input type="checkbox"/> Requested by Customers <input checked="" type="checkbox"/> Products need durability estimation
High Temp. & High Humidity	/	√	
Operation Life	/	√	

CHARACTERISTIC CURVES

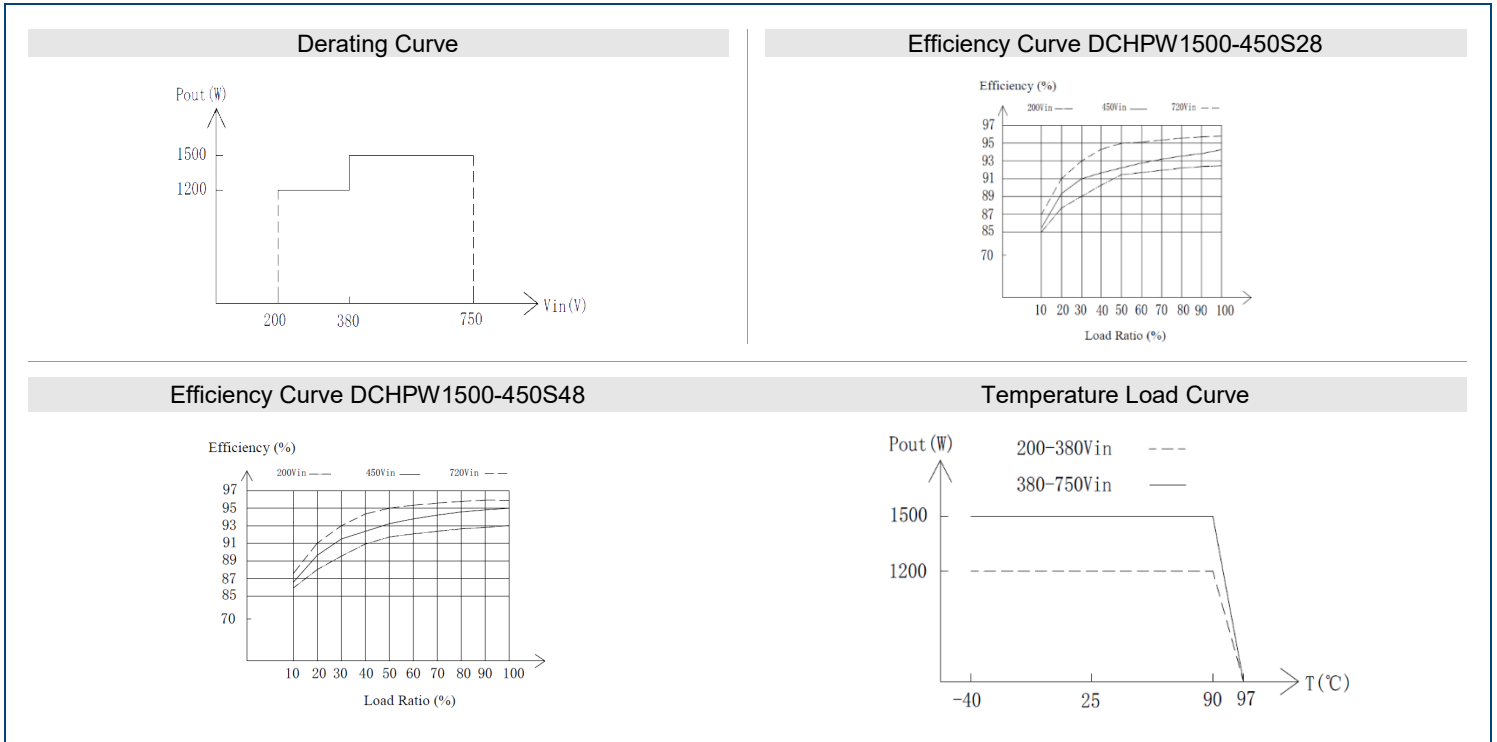

MECHANICAL DRAWINGS

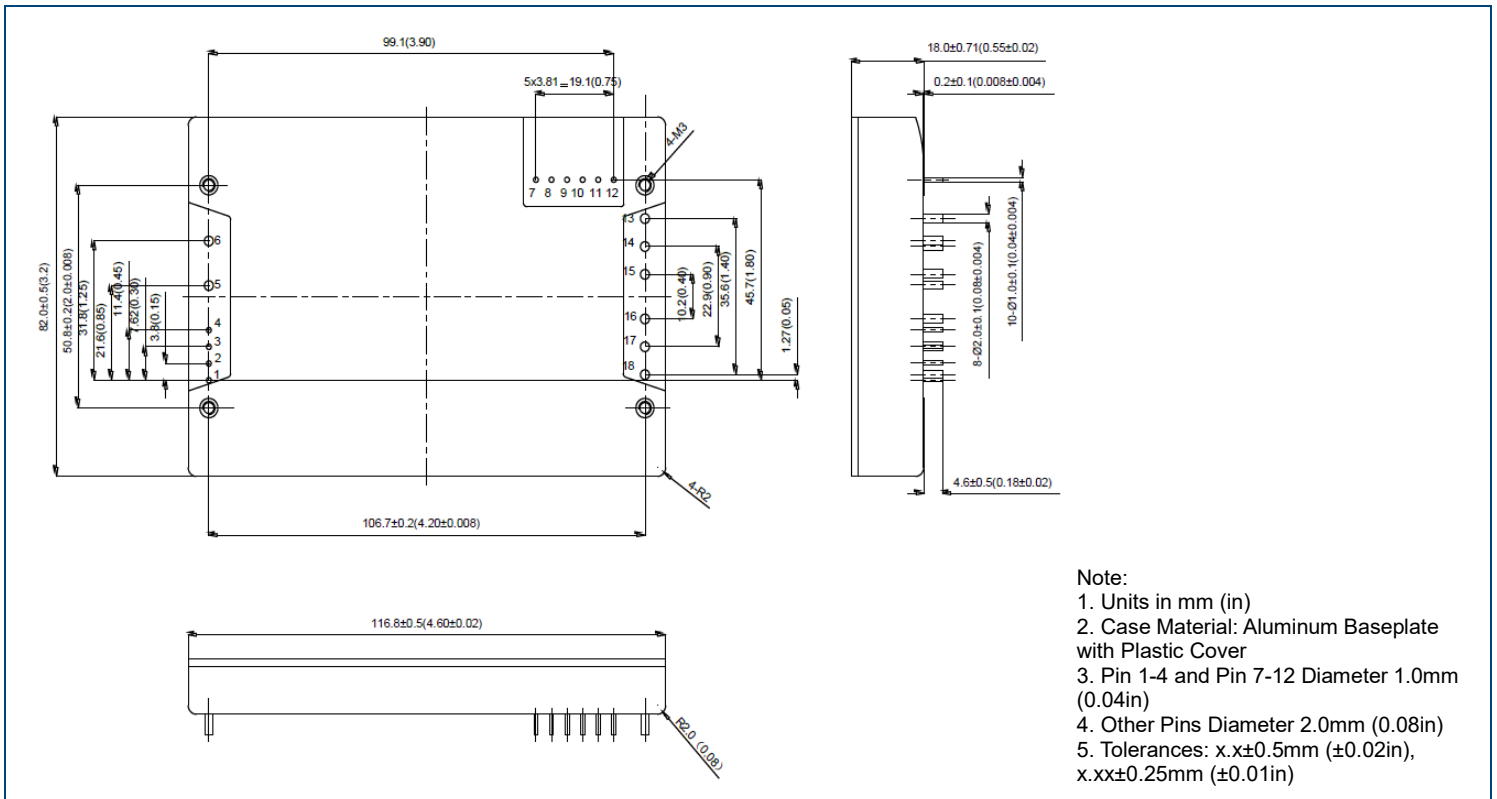

PIN DEFINITION

PIN	NAME	FUNCTION
1	NC	No Connection
2	NC	No Connection
3	ON/OFF (+)	Remote ON/OFF +
4	ON/OFF (-)	Remote ON/OFF -
5	Vin (+)	Input Positive
6	Vin (-)	Input Negative
7	Vaux	Auxiliary Power Supply Positive (Ground Reference Vout (-))
8	Start_Sync	Sync Starting PIN (Option)
9	Ishare	Parallel Current Sharing
10	Trim	Output Voltage Adjustment
11	S (+)	Remote Sense Pin (Positive)
12	S (-)	Remote Sense Pin (Negative)
13, 14, 15	Vout (-)	Output Negative
16, 17, 18	Vout (+)	Output Positive

PACKAGE, STORAGE & TRANSPORTATION

Packaging Requirements

- Packaging should prevent the modules from corrosion, degrading, and mechanical damaging during transportation.
- Keep the modules clean and dry.
- Packaging and shock absorbing materials should not generate static electricity and should be anti-corrosion
- Unless specified, number of modules in package will be determined by the manufacturer.
- There is a standard shape and dimension for the intermediate package which will minimize weight and size.
- Labels are required at outer package.

Storage Requirements

- Unused modules should be kept in the packaging box. The storage environment should be free from corrosive gases, ventilated with relative humidity lower than 80% and storage temp. -10~40°C.
- Packaging boxes should be kept 20cm above ground level, at least 50cm from walls, heat sources, vents and windows.
- Under captioned conditions, storage period is 2 years. It is recommended to re-qualify the modules after 2 years storage.

Transportation Requirements

- Products should be packaged in a strong box during transportation.
- Outer box surface should meet relevant international standards with "Handle with Care" mark and "Keep Dry" mark.
- Package should be made suitable for any common means of transportation. During transportation, the packages should avoid mechanical shocks and should avoid direct exposure to rain and snow.

APPLICATION NOTES

Typical Application Circuit

The built in EMI filter meets the general EMI requirements of most applications. However, if the applications need to meet higher EMI standards, customers can add external EMI filters at the input terminals as shown in Fig. 1.

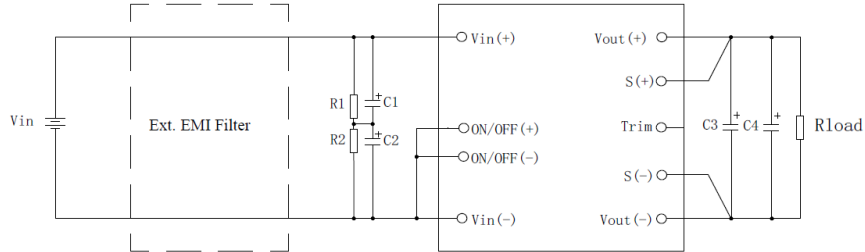

Fig. 1 Typical Application Circuit

Recommended Value

Component	Notes/Specifications		
R1, R2	1MΩ, 1/2W		
C1, C2	Good transient response, low ESR, Electrolytic capacitors 100μF/450V		
C3	Solid Capacitor	DCHPW1500-450S28	2000μF/50V
		DCHPW1500-450S48	1500μF/63V
C4	Solid Capacitor	DCHPW1500-450S28	2000uF/50V
		DCHPW1500-450S48	1500μF/63V

- Note:
- When the ambient temp. is below -25°C, a 3000μF solid capacitor is required at the output for DCHPW1500-450S28 model. A 2000μF solid capacitor is required at the output for DCHPW1500-450S48 model. If higher output capacitance is required, it is recommended to add electrolytic capacitors for stability and reliability concerns.
 - When ambient temps is below -25°C and the input is rising rapidly (more than 10VDC/μs), it is recommended to add at least one 2.2μF/1000VDC (CBB Cap) input capacitor with a minimum total input capacitance not less than 47μF (Test Condition: 10KHz, -55°C) or other external surge protection circuit to prevent excessive surge voltage damaging the module. Please make sure you test actual results in your applications.
 - When adding external EMI filters, please pay attention to the input capacitance matching to avoid excessive surge voltage damaging module.
 - There is no fuse built inside the module. For safety, it is recommended to connect a 20A fast blow fuse at Vin (+) when Vin (-) is connected to ground; at Vin (-) when Vin (+) is connected to ground.
 - The distances between the fuse and module should be minimized.
 - Please use capacitors with appropriate impulse current value.

On/Off Control

ON/OFF Control: Negative Remote On/Off Logic

Logic	Voltage at ON/OFF Pin		
	Logic Low	Open Circuit	Logic High
Negative	Module Enable	Module Enable	Module Disable

Logic On/Off Application:

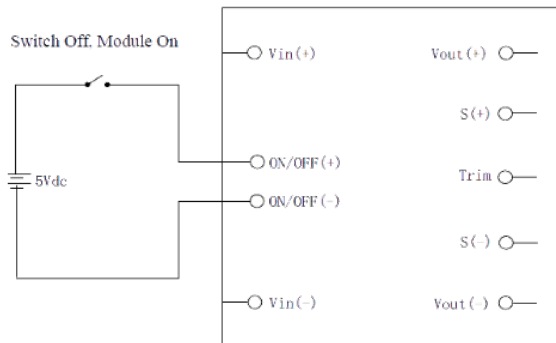

Fig. 2 Remote On/Off Application

Input Reflected Ripple Current

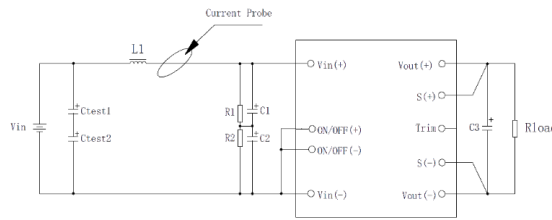

Fig. 3 Input Reflected Ripple Current Test

Note:

- Oscilloscope BW=20MHz
- L1: 12μH/100KHz
- Ctest1 Ctest2: 470μF/450V, High Frequency Low ESR Electrolytic Capacitors
- C1, C2: Tc=25°C, 100μF/450V, High Frequency Low ESR Electrolytic Capacitors
- R1, R2: 1MΩ, 1/2W
- C3: DCHPW1500-450S28: 4000μF/50V, Solid Capacitor; DCHPW1500-450S48: 3000μF/63V, Solid Capacitors

Output Voltage Ripple and Noise

Full load at nominal input voltage and test input voltage from low line to high line. See Fig. 4 for test setup.



Fig. 4 Output Ripple & Noise Test

Note:

- Oscilloscope BW=20MHz
 - C2: 4000μF/50V Solid or Polymer Cap
 - C3: 1μF/50V Ceramic Capacitor
 - C4: 10μF/50V Tantalum Capacitor
- For lower ripple and noise applications, add EMI filter at input and output sides.

Note:

- Oscilloscope BW=20MHz
 - C3: 3000μF/63V Solid or Polymer Cap
 - C4: 1μF/63V Ceramic Capacitor
 - C5: 10μF/63V Tantalum Capacitor
- For lower ripple and noise applications, add EMI filter at input and output sides.

Output Voltage Trimming

Connect external resistor between Trim and Sense (+) or between Trim and Sense (-) to adjust the output voltage between 25.2V to 30.8V. Trim up voltage with a resistor connected between Trim and Sense (+) and trim down the voltage with a resistor connected between Trim and Sense (-). The trim resistor should be connected as close to the module pins as possible. Leave the Trim pin open if no voltage trimming is required. Unless specified, output voltage can be trimmed ±10%

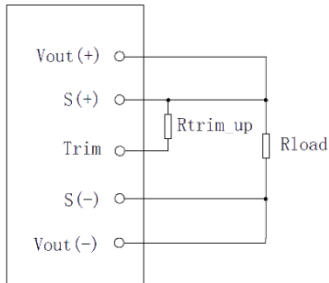

Fig. 5 Output Voltage Trim Up Circuit

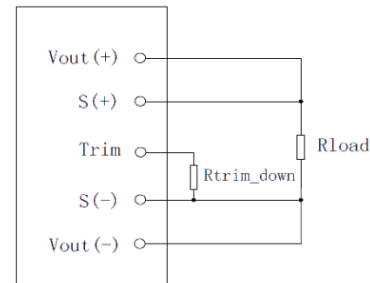

Fig. 6 Output Voltage Trim Down Circuit

Calculating Trim Up Resistance:

$$R_{trim_up} = \frac{V_{out_norm} \times (100 + \Delta)}{1.225 \times \Delta} - \frac{100}{\Delta} - 2$$

Calculating Trim Down Resistance:

$$R_{trim_down} = \frac{100}{\Delta} - 2$$

To trim up 10%, $\Delta=10$, output voltage is 30.8VDC (DCHPW1500-450S28) or 52.8VDC (DCHPW1500-450S48). Put $\Delta=10$ in the above formula to calculate the trim up resistor value:

DCHPW1500-450S28:

$$R_{trim_up} = \frac{28 * (100 + 10)}{1.225 * 10} - \frac{100}{10} - 2 = 239.43$$

DCHPW1500-450S48:

$$R_{trim_up} = \frac{48 * (100 + 10)}{1.225 * 10} - \frac{100}{10} - 2 = 419.0$$

To time down 10%, $\Delta=10$, output voltage is 25.2VDC, Put $\Delta=10$ in the above formula to calculate the trim down resistor value:

$$R_{trim_down} = \frac{100}{10} - 2 = 8$$

Note:

$$\Delta = \left| \frac{V_{out} - V_{out_norm}}{V_{out_norm}} \right| \times 100$$

- Unit of formula is K Ω
- Vout: Desired Output Voltage
- Vout_norm: Nominal output voltage 28V
- The maximum power of the module is fixed. If output voltage increases, maximum current has to be reduced.
- The maximum current of the module is fixed. If output voltage decrease, maximum output current will not change.
- The maximum output voltage cannot exceed 30.8VDC (DCHPW1500-450S28) or 52.8VDC (DCHPW1500-450S48).
- If input voltage is between 650VDC-700VDC, the output voltage can only be trimmed down.
- If input voltage is between 700VDC-750VDC, the output voltage can only be trimmed up.
- If input voltage is between 620-650VDC, the output voltage can only be trimmed down 5%Vout.

Output Remote Sensing

The module built in remote voltage compensation function to compensate the line voltage drop. As shown in Fig. 7, connect Sense (+) and Sense (-) to the terminals of the load through a twisted pair. The voltage at the terminals of the load is regulated at the nominal output voltage of the module. If no remote voltage compensation is required, connect Sense (+) to Vout (+) directly and connect Sense (-) to Vout (-) directly.

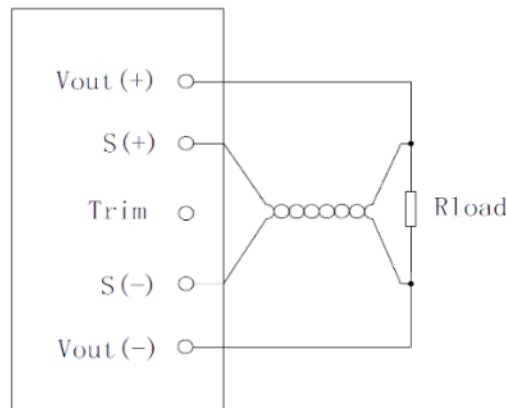

Fig. 7 Output Remote Sensing

- Note:
- Max. output voltage of the module cannot exceed 110% of the nominal output voltage. Max. output voltage cannot exceed 30.8VDC (DCHPW1500-450S28) or 52.8VDC (DCHPW1500-450S48)
 - Polarity of Sense (+) and Sense (-) must be the same as output voltage, otherwise modules will enter protection mode.
 - Max. power of module is fixed. If output voltage increases, max. output current has to be reduced.

Parallel Operation

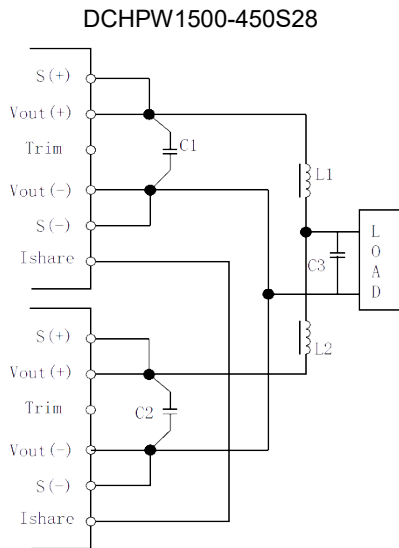

Fig. 8.1 DCHPW1500-450S28 Parallel Operation

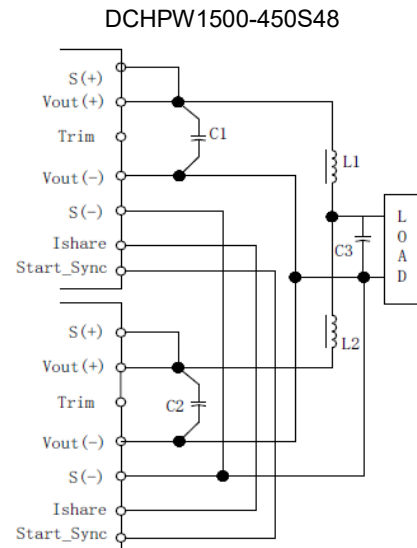

Fig. 8.2 DCHPW1500-450S48 Parallel Operation

Parallel: For paralleling the outputs of n modules, please connect the Ishare (Parallel Current Sharing) pins of the modules together and make sure the Ishare connecting lines are free from interference. When connecting the output pins of the modules together, please make sure the output impedance of the output lines are balanced. A maximum of 10 modules can be connected in parallel (Fig 8).

n+1 Redundant Paralleling: For paralleling the outputs of n modules, please connect the Ishare (Parallel Current Sharing) pins of the modules together and make sure the Ishare connecting lines are free from interference. Please also connect the Start_Sync (Sync Starting) pins of the modules together. When connecting the output pins of the modules together, please make sure the output impedance of the output lines are balanced. A maximum of 10 modules can be connected in parallel. (Fig. 8.2)

Note: Formula to calculate the parallel current sharing accuracy

- n: Number of paralleling modules
- i: Module to calculate the load share accuracy
- I1, I2...Ii...In (2≤n≤10): Output current of each module
- Ie: Nominal output current of each module
- ΣI: Total output current of n modules
- nIe: Total nominal output current of n modules

Output Over Current & Short Circuit Protection

When the output is overloaded or short circuit and the output voltage is over the pre-set value (around 20V, 25V maximum for DCHPW1500-450S28, around 35V, 43V maximum for DCHPW1500-450S48), the module will enter protection mode with constant output current. If output voltage is over the pre-set value (around 20V, 25V maximum for DCHPW1500-450S28, around 35V, 43V maximum for DCHPW1500-450S48), the output will be in hiccup mode. It will restart automatically when the fault is removed.

Output Over Voltage Protection (OVP)

When the output voltage exceeds the over voltage set point, the module will shut down. It is a latch mode and the input has to be reset or use Remote CNT pin to restart.

Over Temperature Protection

When the PCB temperature near the thermistor reaches the temperature set point 97°C (typical value), it triggers the over temperature protection. Output voltage will shut down. When PCB temperature lowers to 87°C (typical value), output resumes automatically.

USER INFORMATION

Please read the Warning and Important Notices section before using the modules. Any mis-operation can cause fire hazard or damages to the modules.

Warning

- When the module is powered up, please keep your body away from the module to avoid accidental injury.
- Please do not modify or disassemble the module. This may cause electric shock. If customer modifies or disassembles the module, we are not responsible for any resulting consequences.
- There are high voltage spots and high temperature spots inside the module. Please do not touch any internal component to avoid electric shock or burn.
- When module is powered up, do not touch the module to avoid burns.

Important Notices

- Make sure that the input/output terminals and signal pins of the module are connected appropriately according to the application note/datasheet. Do not apply power when wiring the pins.
- A fast blow 10A fuse or other over current protection device must be connected to the input terminal of the module.
- The schematics and parameters of the module are for reference only. Customers have to verify these schematics and the effective value of the parameters before they finish the circuit design.
- Please use the module within indicated specifications. Stress above the specifications will cause permanent damages to the product.
- Users must consider the potential electrical hazards of the output terminals. They are responsible for the appropriate design to avoid accidental contact from people or objects during operation.
- Wall Industries, Inc. reserves the right for the interpretation of this document. Any redistribution or reproduction of part or all of the contents in any form is prohibited without permission from Wall Industries, Inc.

COMPANY INFORMATION

Wall Industries, Inc. has created custom and modified units for over 50 years. Our in-house research and development engineers will provide a solution that exceeds your performance requirements on-time and on budget. Our ISO9001: 2015 certification is just one example of our commitment to producing a high quality, well-documented product for our customers.

Our past projects demonstrate our commitment to you, our customer. Wall Industries, Inc. has a reputation for working closely with its customers to ensure each solution meets or exceeds form, fit and function requirements. We will continue to provide ongoing support for your project above and beyond the design and production phases. Give us a call today to discuss your future projects.

Contact **Wall Industries** for further information:

Phone: ☎(603)778-2300
Toll Free: ☎(888)597-9255
Fax: ☎(603)778-9797
E-mail: sales@wallindustries.com
Web: www.wallindustries.com
Address: 37 Industrial Drive
Exeter, NH 03833

©2019 Wall Industries, Inc. Specifications subject to change without notice. Wall Industries is not responsible for typographical errors. The information contained herein is for informational purposes only. This information is provided by Wall Industries and we make no representations or warranties of any kind, express or implied, about the completeness, accuracy, reliability, suitability or availability with respect to the information contained in this document for any purpose. All product and manufacturer names are trademarks or registered trademarks of their respective companies.