

flowPACK 0 3rd gen
1200V/25A
Features

- 2 clip housing in 12mm and 17mm height
- Trench Fieldstop IGBT⁴ technology
- Compact and low inductance design
- Built-in NTC

Target Applications

- Motor Drives
- Power Generation
- UPS

Types

- V23990-P869-F49-PM: 17mm height
- V23990-P869-F48-PM: 12mm height

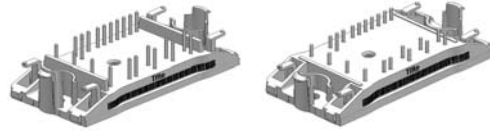
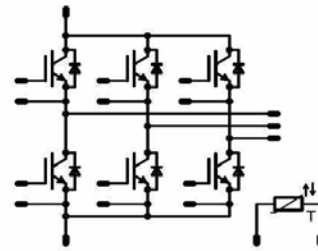
flow0 housing

Schematic

Maximum Ratings

 T_j=25°C, unless otherwise specified

Parameter	Symbol	Condition	Value	Unit
Inverter Transistor				
Collector-emitter voltage	V _{CE}		1200	V
DC collector current	I _C	T _j =T _{jmax} T _h =80°C T _c =80°C	28	A
Repetitive peak collector current	I _{Cpulse}	t _p limited by T _{jmax}	75	A
Power dissipation per IGBT	P _{tot}	T _j =T _{jmax} T _h =80°C T _c =80°C	73	W
Gate-emitter peak voltage	V _{GE}		±20	V
Short circuit ratings*	t _{SC} V _{CC}	T _j ≤150°C V _{GE} =15V	10 800	µs V
Maximum Junction Temperature	T _{jmax}		175	°C

* It is recommended to not exceed 1000 short circuit situations in the lifetime of the module and to allow at least 1s between short circuits

Inverter Diode

Peak Repetitive Reverse Voltage	V _{RRM}	T _j =25°C	1200	V
DC forward current	I _F	T _j =T _{jmax} T _h =80°C T _c =80°C	27	A
Repetitive peak forward current	I _{FRM}	t _p limited by T _{jmax}	50	A
Power dissipation per Diode	P _{tot}	T _j =T _{jmax} T _h =80°C T _c =80°C	51	W
Maximum Junction Temperature	T _{jmax}		175	°C

Thermal properties

Storage temperature	T _{stg}		-40.....+125	°C
Operation junction temperature	T _{op}		-40.....+T _{jmax} -25	°C

Maximum Ratings

T_j=25°C, unless otherwise specified

Parameter	Symbol	Condition	Value	Unit
Insulation properties				
Insulation voltage	V _{is}	t=2s DC voltage	4000	V
Creepage distance			min.12,7	mm
Clearance			min.12,7	mm

Characteristic Values

Parameter	Symbol	Conditions					Value			Unit	
		$V_{GE} [V]$ or $V_{GS} [V]$	$V_r [V]$ or $V_{CE} [V]$ or $V_{DS} [V]$	$I_c [A]$ or $I_F [A]$ or $I_D [A]$	T_j	Min	Typ	Max			
Inverter Transistor											
Gate emitter threshold voltage	$V_{GE(th)}$	VCE=VGE			0,00085	T _J =25°C T _J =150°C	5	5,8	6,5	V	
Collector-emitter saturation voltage	$V_{CE(sat)}$		15		25	T _J =25°C T _J =150°C		1,91 2,33	2,4	V	
Collector-emitter cut-off current incl. Diode	I_{CES}		0	1200		T _J =25°C T _J =150°C			10	μA	
Gate-emitter leakage current	I_{GES}		20	0		T _J =25°C T _J =150°C			200	nA	
Integrated Gate resistor	R_{gint}							none		Ω	
Turn-on delay time	$t_{d(on)}$	R _{gon} =32Ω R _{goff} =32Ω	±15	600	25	T _J =25°C T _J =150°C		130 127		ns	
Rise time	t_r					T _J =25°C T _J =150°C		26 32			
Turn-off delay time	$t_{d(off)}$					T _J =25°C T _J =150°C		220 286			
Fall time	t_f					T _J =25°C T _J =150°C		77 118			
Turn-on energy loss per pulse	E_{on}					T _J =25°C T _J =150°C					2,001 3,002
Turn-off energy loss per pulse	E_{off}	T _J =25°C T _J =150°C				1,32 2,16					
Input capacitance	C_{ies}							1430		pF	
Output capacitance	C_{oss}	f=1MHz	0	25		T _J =25°C		115			
Reverse transfer capacitance	C_{rss}							85			
Gate charge	Q_{Gate}		15	960	25	T _J =25°C		120		nC	
Thermal resistance chip to heatsink per chip	R_{thJH}	Thermal grease thickness≤50um λ = 0,61 W/mK						1,305		K/W	
Inverter Diode											
Diode forward voltage	V_F				25	T _J =25°C T _J =150°C		1,87 1,80	2,35	V	
Reverse leakage current	I_R					T _J =25°C T _J =150°C			10	μA	
Peak reverse recovery current	I_{RRM}	R _{gon} =32Ω	±15	600	25	T _J =25°C T _J =150°C		18,3 21,7		A	
Reverse recovery time	t_{rr}					T _J =25°C T _J =150°C		360 588			
Reverse recovered charge	Q_{rr}					T _J =25°C T _J =150°C		2,41 4,94			μC
Peak rate of fall of recovery current	$di(rec)max/dt$					T _J =25°C T _J =150°C		75 48			A/μs
Reverse recovered energy	E_{rec}					T _J =150°C					1,971
Thermal resistance chip to heatsink per chip	R_{thJH}	Thermal grease thickness≤50um λ = 0,61 W/mK						1,851		K/W	
Thermistor											
Rated resistance	R_{25}	Tol. ±5%				T _J =25°C	20,9	22	23,1	kΩ	
Deviation of R100	$\Delta R/R$	R100=1486Ω				T _J =100°C		2,9		%/K	
Power dissipation	P					T _J =25°C		210		mW	
B-value	$B_{(25/100)}$	Tol. ±3%				T _J =25°C		4000		K	

Output Inverter

Figure 1 Output inverter IGBT

Typical output characteristics

$I_C = f(V_{CE})$

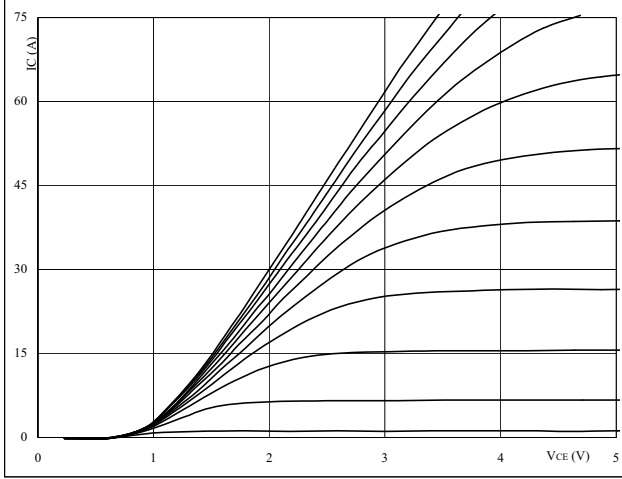

$t_p = 250 \mu s$
 $T_j = 25 \text{ }^\circ C$
 V_{GE} from 7 V to 17 V in steps of 1 V

Figure 2 Output inverter IGBT

Typical output characteristics

$I_C = f(V_{CE})$

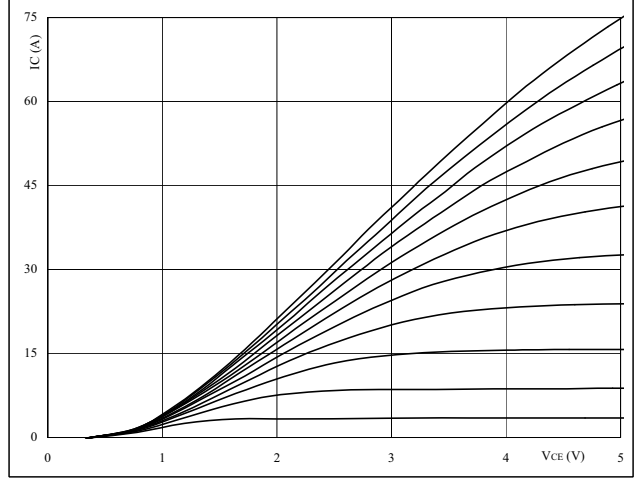

$t_p = 250 \mu s$
 $T_j = 150 \text{ }^\circ C$
 V_{GE} from 7 V to 17 V in steps of 1 V

Figure 3 Output inverter IGBT

Typical transfer characteristics

$I_C = f(V_{GE})$

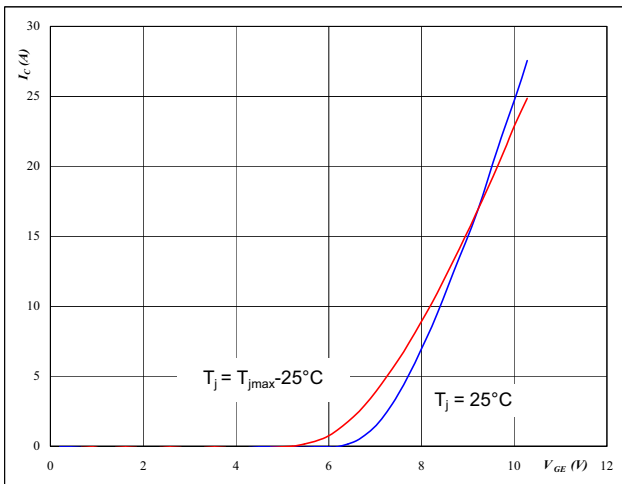

$t_p = 250 \mu s$
 $V_{CE} = 10 \text{ V}$

Figure 4 Output inverter FRED

Typical diode forward current as a function of forward voltage

$I_F = f(V_F)$

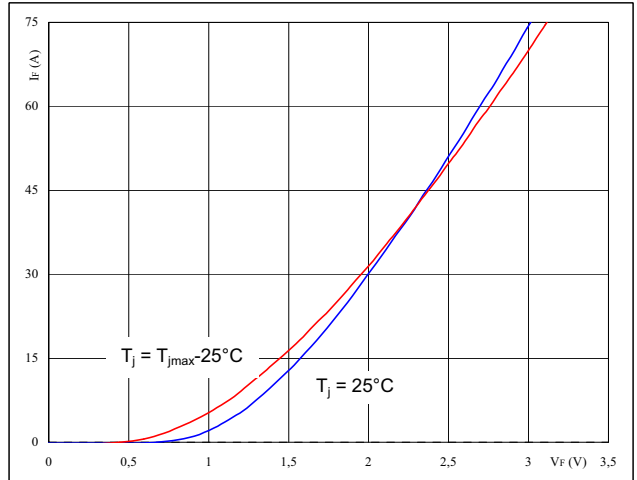

$t_p = 250 \mu s$

Output Inverter

Figure 5 Output inverter IGBT

Typical switching energy losses as a function of collector current
 $E = f(I_C)$

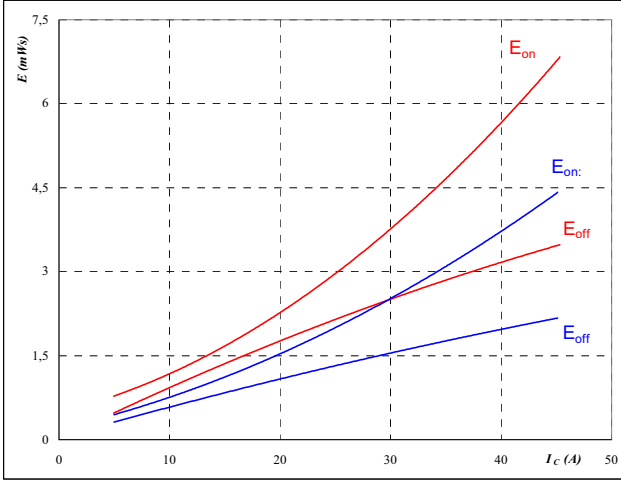

inductive load
 $T_J = 25/150$ °C
 $V_{CE} = 600$ V
 $V_{GE} = \pm 15$ V
 $R_{gon} = 32$ Ω
 $R_{goff} = 32$ Ω

Figure 6 Output inverter IGBT

Typical switching energy losses as a function of gate resistor
 $E = f(R_G)$

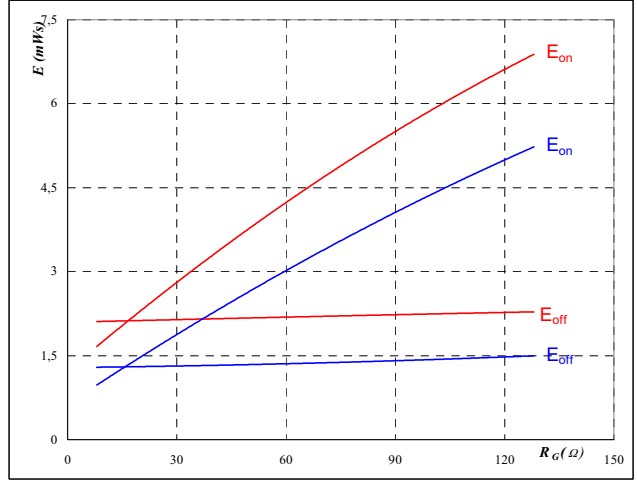

inductive load
 $T_J = 25/150$ °C
 $V_{CE} = 600$ V
 $V_{GE} = \pm 15$ V
 $I_C = 25$ A

Figure 7 Output inverter IGBT

Typical reverse recovery energy loss as a function of collector current
 $E_{rec} = f(I_C)$

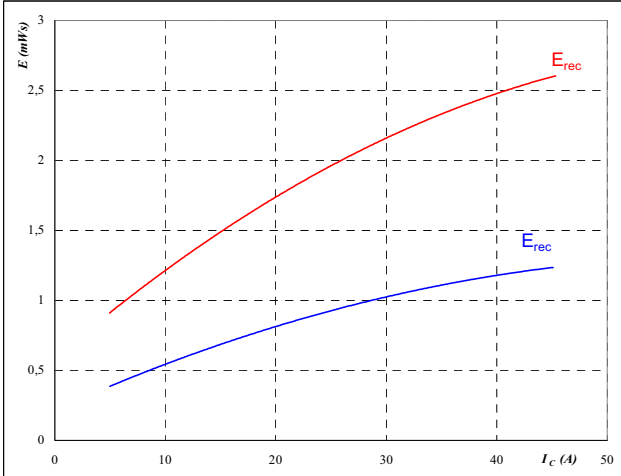

inductive load
 $T_J = 25/150$ °C
 $V_{CE} = 600$ V
 $V_{GE} = \pm 15$ V
 $R_{gon} = 32$ Ω

Figure 8 Output inverter IGBT

Typical reverse recovery energy loss as a function of gate resistor
 $E_{rec} = f(R_G)$

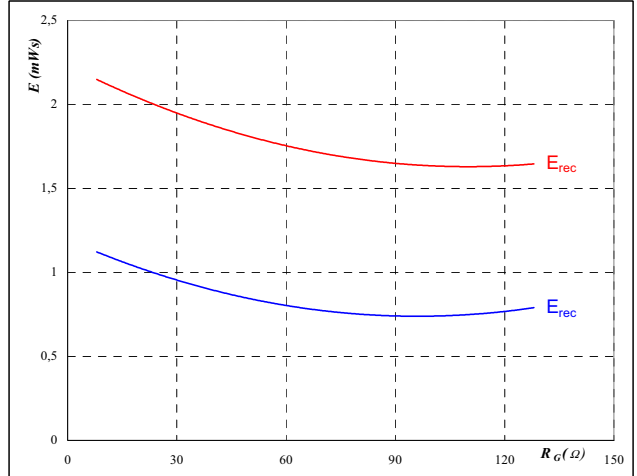

inductive load
 $T_J = 25/150$ °C
 $V_{CE} = 600$ V
 $V_{GE} = \pm 15$ V
 $I_C = 25$ A

Output Inverter

Figure 9 Output inverter IGBT

Typical switching times as a function of collector current

$$t = f(I_C)$$

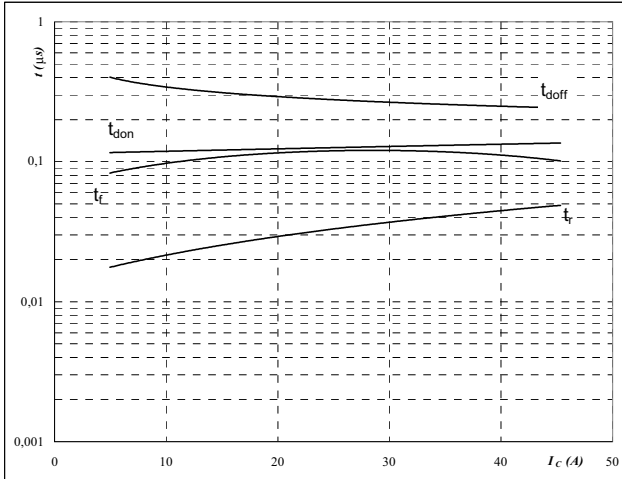

inductive load

$T_J =$	150	°C
$V_{CE} =$	600	V
$V_{GE} =$	±15	V
$R_{gon} =$	32	Ω
$R_{goff} =$	32	Ω

Figure 10 Output inverter IGBT

Typical switching times as a function of gate resistor

$$t = f(R_G)$$

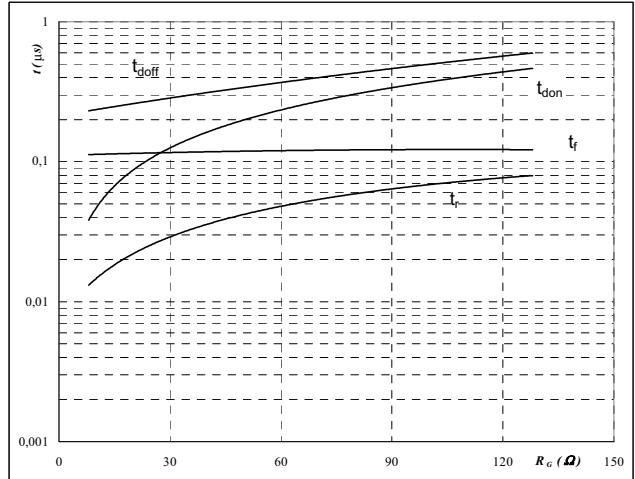

inductive load

$T_J =$	150	°C
$V_{CE} =$	600	V
$V_{GE} =$	±15	V
$I_C =$	25	A

Figure 11 Output inverter FRED

Typical reverse recovery time as a function of collector current

$$t_{rr} = f(I_C)$$

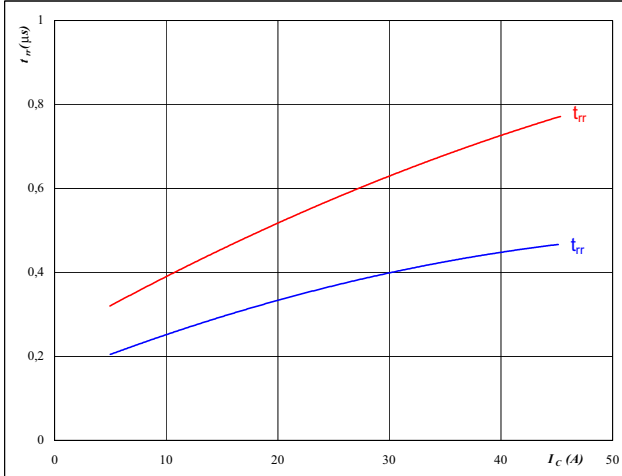

$T_J =$	25/150	°C
$V_{CE} =$	600	V
$V_{GE} =$	±15	V
$R_{gon} =$	32	Ω

Figure 12 Output inverter FRED

Typical reverse recovery time as a function of IGBT turn on gate resistor

$$t_{rr} = f(R_{gon})$$

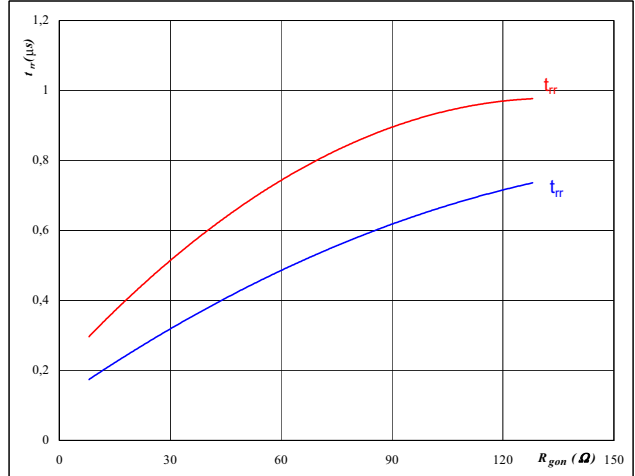

$T_J =$	25/150	°C
$V_R =$	600	V
$I_F =$	25	A
$V_{GE} =$	±15	V

Output Inverter

Figure 13 Output inverter FRED

Typical reverse recovery charge as a function of collector current

$$Q_{rr} = f(I_C)$$

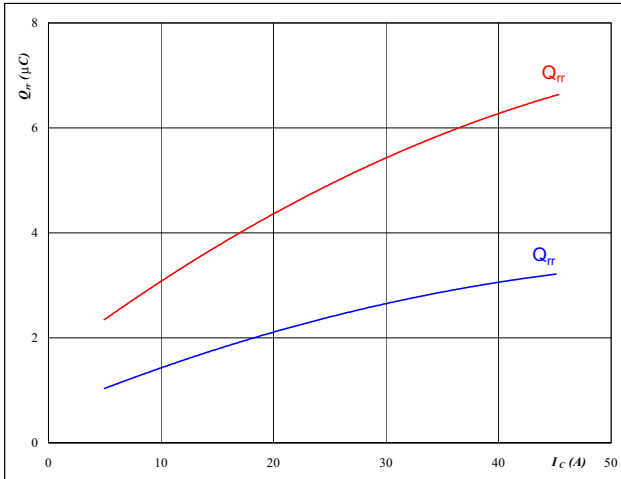

$T_J = 25/150 \text{ } ^\circ\text{C}$
 $V_{CE} = 600 \text{ V}$
 $V_{GE} = \pm 15 \text{ V}$
 $R_{gon} = 32 \text{ } \Omega$

Figure 14 Output inverter FRED

Typical reverse recovery charge as a function of IGBT turn on gate resistor

$$Q_{rr} = f(R_{gon})$$

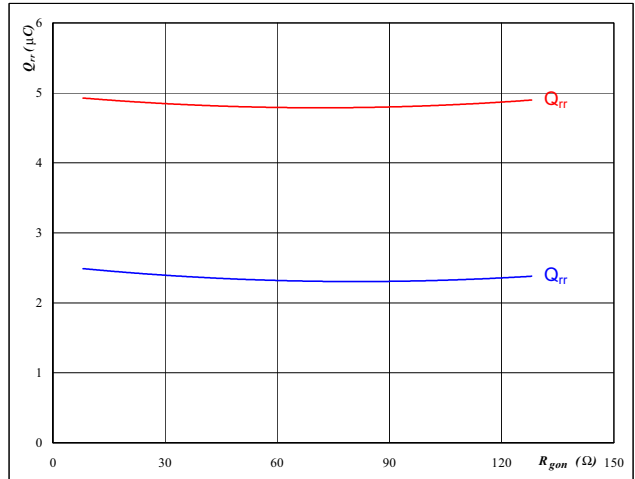

$T_J = 25/150 \text{ } ^\circ\text{C}$
 $V_R = 600 \text{ V}$
 $I_F = 25 \text{ A}$
 $V_{GE} = \pm 15 \text{ V}$

Figure 15 Output inverter FRED

Typical reverse recovery current as a function of collector current

$$I_{RRM} = f(I_C)$$

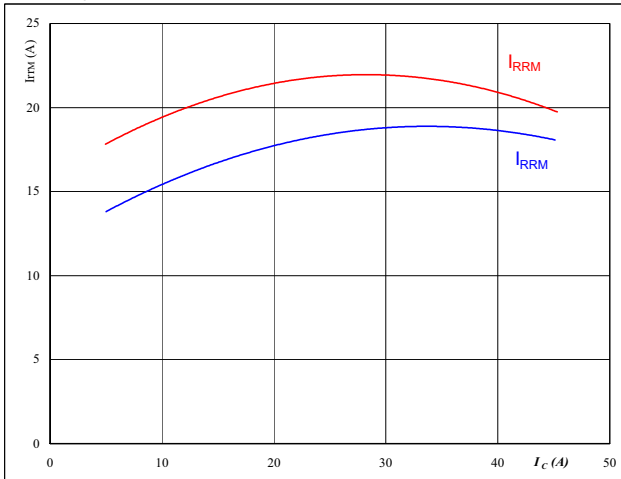

$T_J = 25/150 \text{ } ^\circ\text{C}$
 $V_{CE} = 600 \text{ V}$
 $V_{GE} = \pm 15 \text{ V}$
 $R_{gon} = 32 \text{ } \Omega$

Figure 16 Output inverter FRED

Typical reverse recovery current as a function of IGBT turn on gate resistor

$$I_{RRM} = f(R_{gon})$$

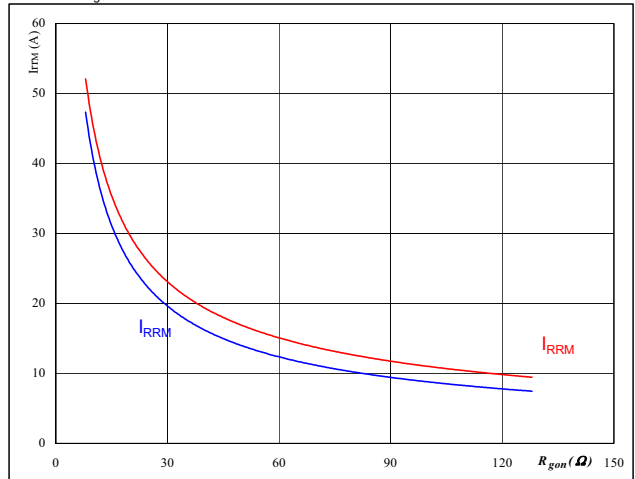

$T_J = 25/150 \text{ } ^\circ\text{C}$
 $V_R = 600 \text{ V}$
 $I_F = 25 \text{ A}$
 $V_{GE} = \pm 15 \text{ V}$

Output Inverter

Figure 17 Output inverter FRED

Typical rate of fall of forward and reverse recovery current as a function of collector current

$$di_o/dt, di_{rec}/dt = f(I_c)$$

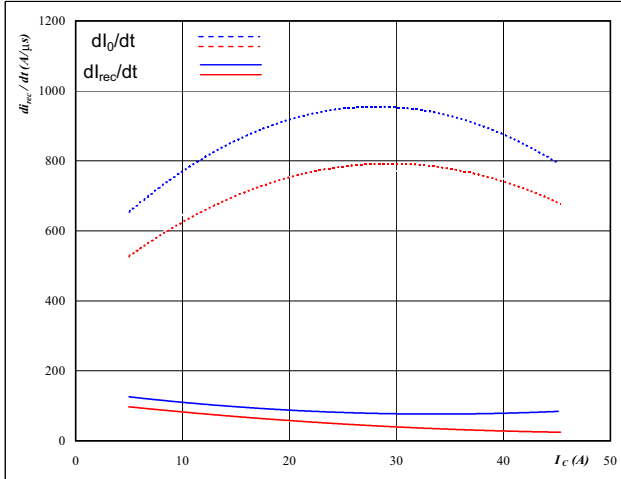

$T_j = 25/150$ °C
 $V_{CE} = 600$ V
 $V_{GE} = \pm 15$ V
 $R_{gon} = 32$ Ω

Figure 18 Output inverter FRED

Typical rate of fall of forward and reverse recovery current as a function of IGBT turn on gate resistor

$$di_o/dt, di_{rec}/dt = f(R_{gon})$$

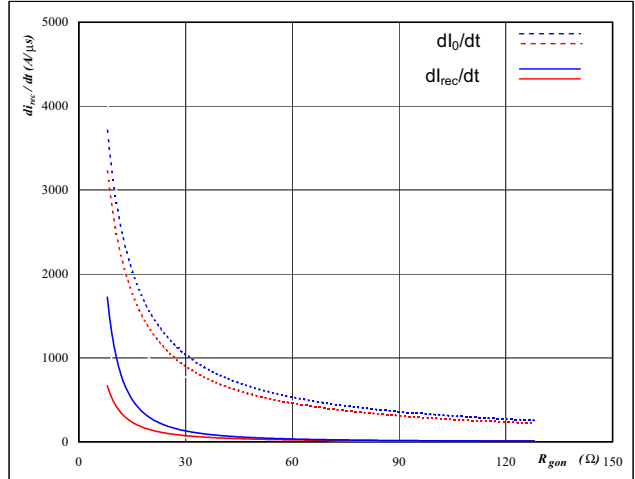

$T_j = 25/150$ °C
 $V_R = 600$ V
 $I_F = 25$ A
 $V_{GE} = \pm 15$ V

Figure 19 Output inverter IGBT

IGBT transient thermal impedance as a function of pulse width

$$Z_{thJH} = f(t_p)$$

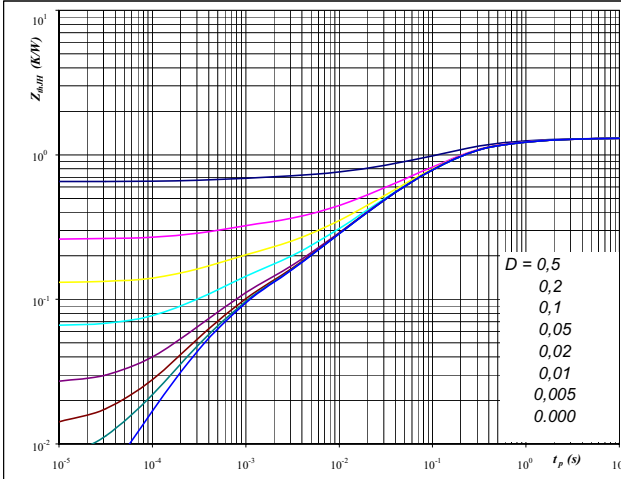

$D = t_p / T$
 $R_{thJH} = 1,31$ K/W

IGBT thermal model values

R (C/W)	Tau (s)
0,06	3,5E+00
0,18	6,2E-01
0,65	1,3E-01
0,27	2,3E-02
0,08	3,9E-03
0,07	4,6E-04

Figure 20 Output inverter FRED

FRED transient thermal impedance as a function of pulse width

$$Z_{thJH} = f(t_p)$$

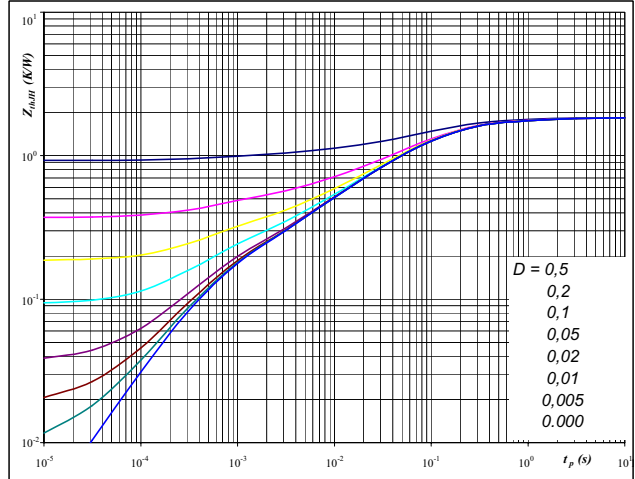

$D = t_p / T$
 $R_{thJH} = 1,85$ K/W

FRED thermal model values

R (C/W)	Tau (s)
0,04	9,4E+00
0,19	8,3E-01
0,80	1,3E-01
0,50	2,9E-02
0,19	4,5E-03
0,13	4,9E-04

Output Inverter

Figure 21 Output inverter IGBT

Power dissipation as a function of heatsink temperature

$$P_{tot} = f(T_h)$$

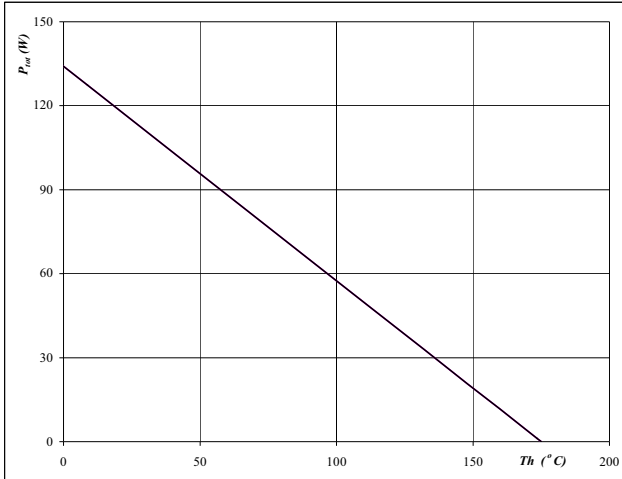

$T_J = 175$ °C

Figure 22 Output inverter IGBT

Collector current as a function of heatsink temperature

$$I_C = f(T_h)$$

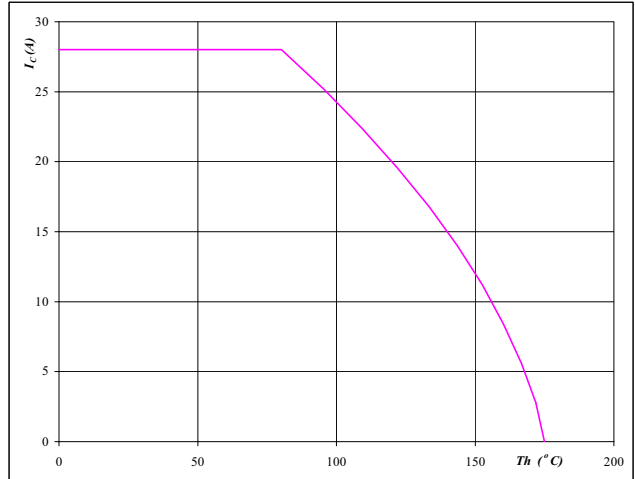

$T_J = 175$ °C
 $V_{GE} = 15$ V

Figure 23 Output inverter FRED

Power dissipation as a function of heatsink temperature

$$P_{tot} = f(T_h)$$

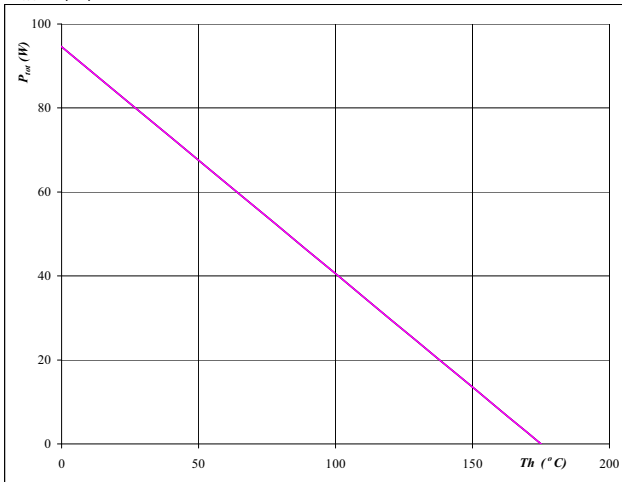

$T_J = 175$ °C

Figure 24 Output inverter FRED

Forward current as a function of heatsink temperature

$$I_F = f(T_h)$$

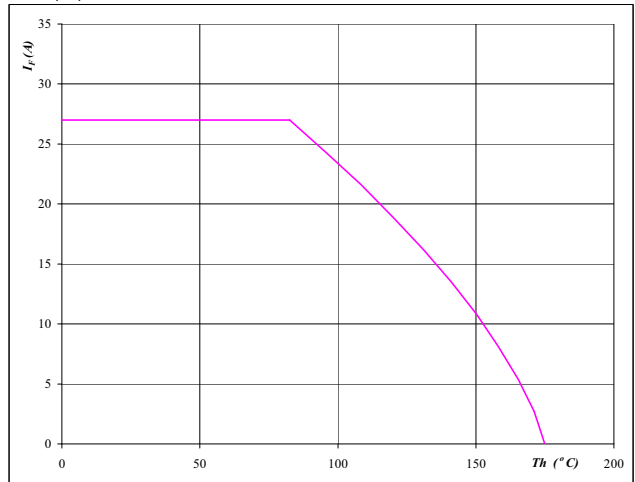

$T_J = 175$ °C

Output Inverter

Figure 25 Output inverter IGBT

Safe operating area as a function of collector-emitter voltage
 $I_C = f(V_{CE})$

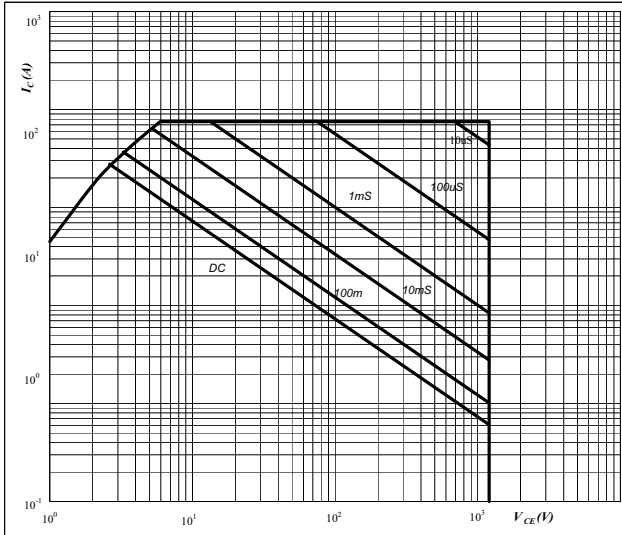

D = single pulse
 $T_n = 80$ °C
 $V_{GE} = \pm 15$ V
 $T_j = T_{jmax}$ °C

Figure 26 Output inverter IGBT

Gate voltage vs Gate charge
 $V_{GE} = f(Q_g)$

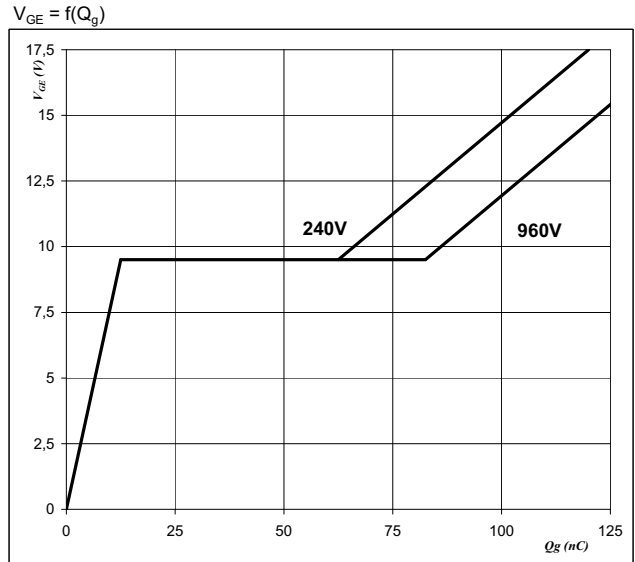

$I_C = 25$ A

Thermistor

Figure 1 Thermistor

Typical NTC characteristic as a function of temperature
 $R_T = f(T)$

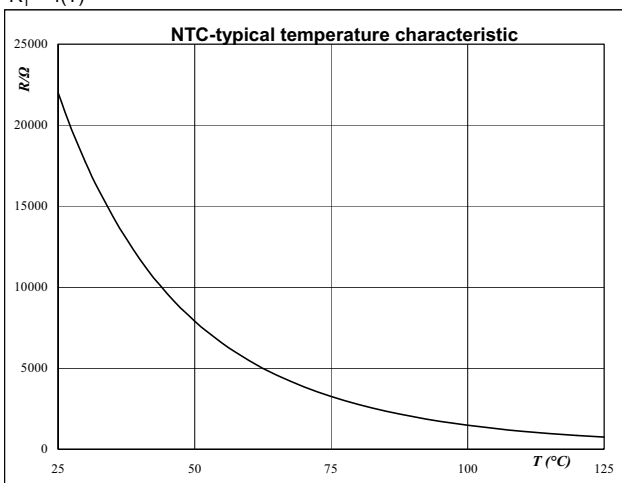

Switching Definitions Output Inverter

General conditions	
T_j	= 150 °C
R_{gon}	= 32 Ω
R_{goff}	= 32 Ω

Figure 1 Output inverter IGBT

Turn-off Switching Waveforms & definition of t_{doff} , t_{Eoff}
(t_{Eoff} = integrating time for E_{off})

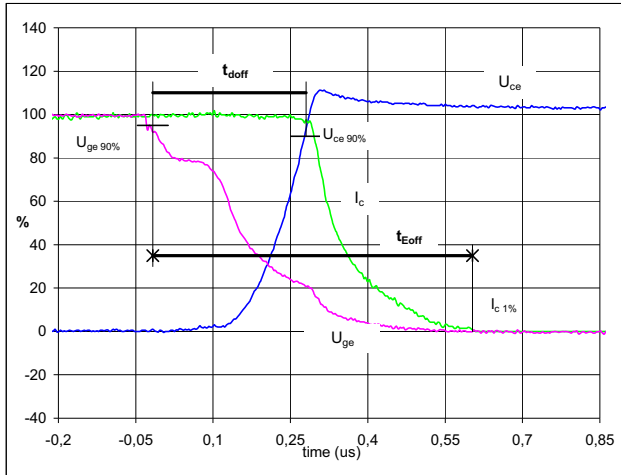

$V_{GE}(0\%)$	=	-15	V
$V_{GE}(100\%)$	=	15	V
$V_C(100\%)$	=	600	V
$I_C(100\%)$	=	25	A
t_{doff}	=	0,29	μs
t_{Eoff}	=	0,62	μs

Figure 2 Output inverter IGBT

Turn-on Switching Waveforms & definition of t_{don} , t_{Eon}
(t_{Eon} = integrating time for E_{on})

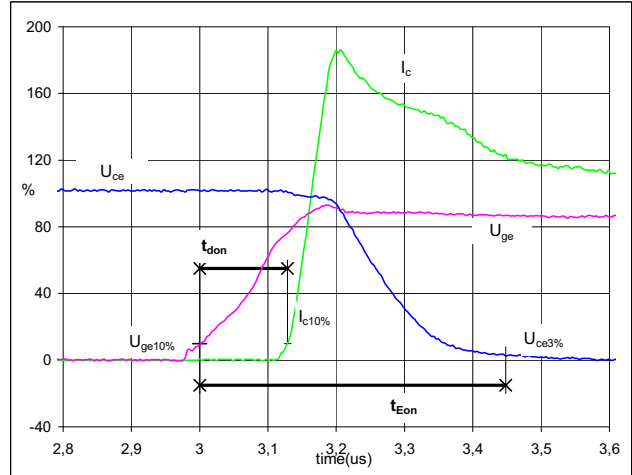

$V_{GE}(0\%)$	=	-15	V
$V_{GE}(100\%)$	=	15	V
$V_C(100\%)$	=	600	V
$I_C(100\%)$	=	25	A
t_{don}	=	0,13	μs
t_{Eon}	=	0,45	μs

Figure 3 Output inverter IGBT

Turn-off Switching Waveforms & definition of t_f

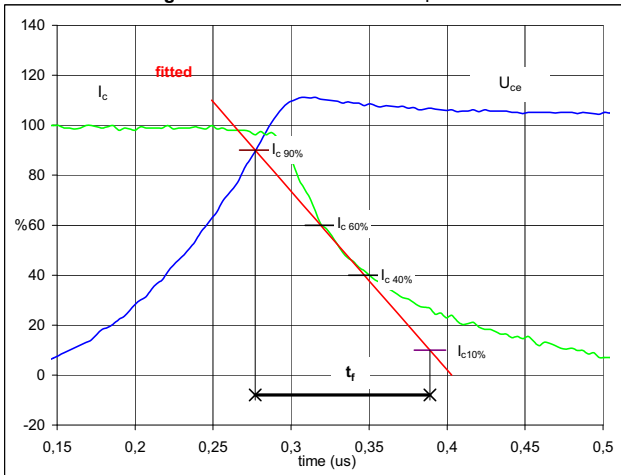

$V_C(100\%)$	=	600	V
$I_C(100\%)$	=	25	A
t_f	=	0,12	μs

Figure 4 Output inverter IGBT

Turn-on Switching Waveforms & definition of t_r

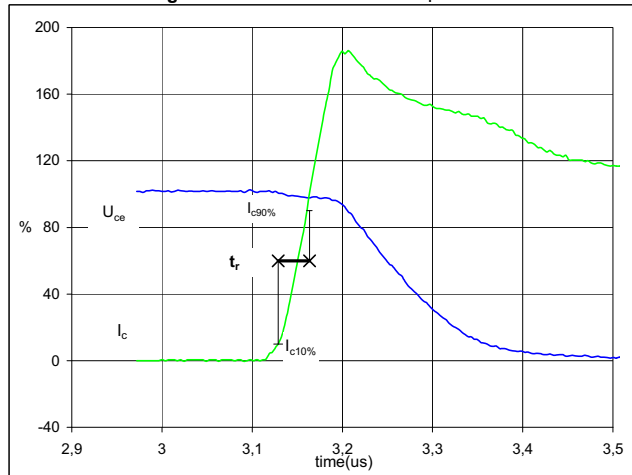

$V_C(100\%)$	=	600	V
$I_C(100\%)$	=	25	A
t_r	=	0,03	μs

Switching Definitions Output Inverter

Figure 5 Output inverter IGBT
Turn-off Switching Waveforms & definition of t_{Eoff}

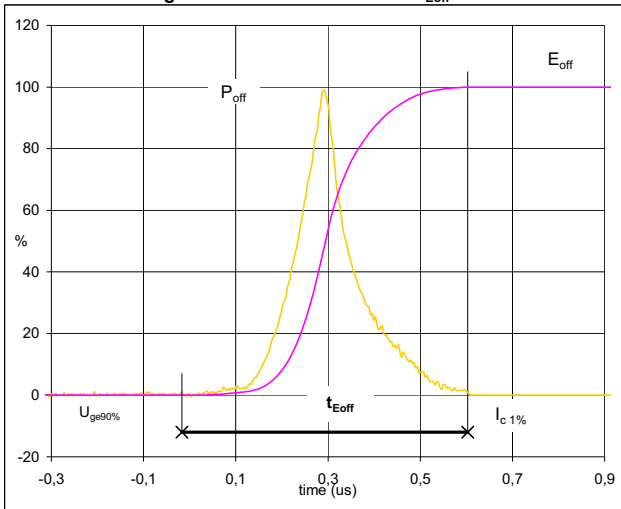

$P_{off}(100\%) = 15,10$ kW
 $E_{off}(100\%) = 2,16$ mJ
 $t_{Eoff} = 0,62$ μ s

Figure 6 Output inverter IGBT
Turn-on Switching Waveforms & definition of t_{Eon}

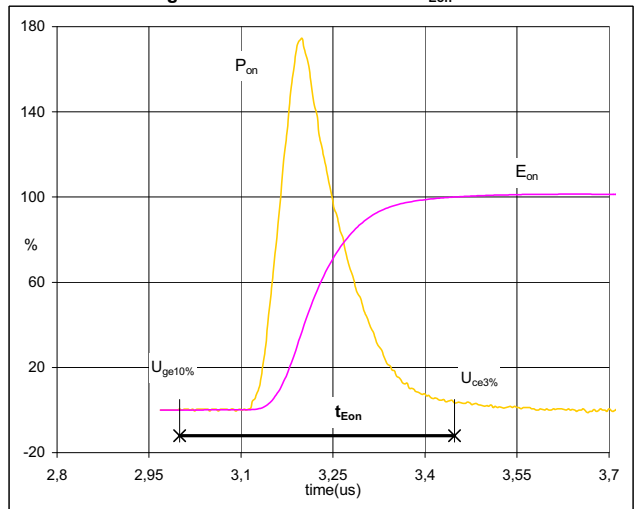

$P_{on}(100\%) = 15,10$ kW
 $E_{on}(100\%) = 3,00$ mJ
 $t_{Eon} = 0,45$ μ s

Figure 7 Output inverter FRED
Gate voltage vs Gate charge (measured)

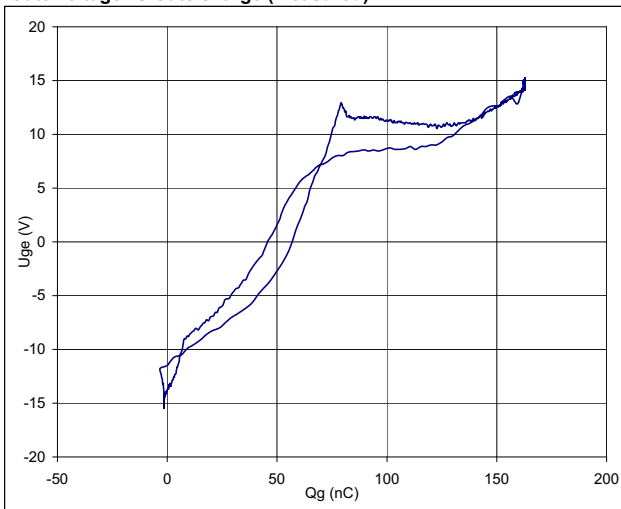

$V_{GEoff} = -15$ V
 $V_{GEon} = 15$ V
 $V_C(100\%) = 600$ V
 $I_C(100\%) = 25$ A
 $Q_g = 678$ nC

Figure 8 Output inverter IGBT
Turn-off Switching Waveforms & definition of t_{rr}

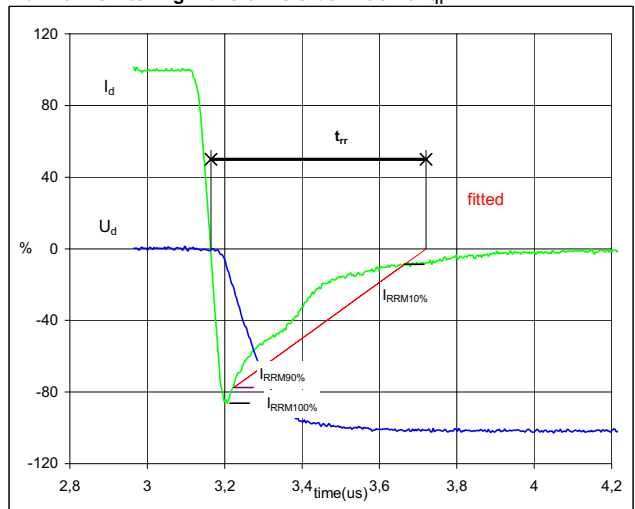

$V_d(100\%) = 600$ V
 $I_d(100\%) = 25$ A
 $I_{RRM}(100\%) = -22$ A
 $t_{rr} = 0,59$ μ s

Switching Definitions Output Inverter

Figure 9 Output inverter FRED

Turn-on Switching Waveforms & definition of t_{Qrr}
(t_{Qrr} = integrating time for Q_{rr})

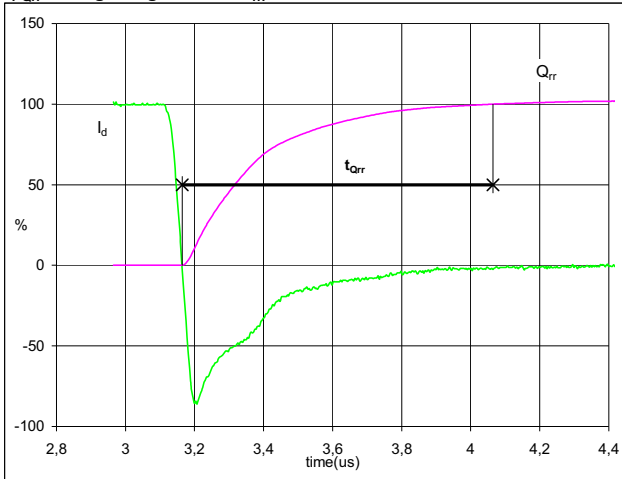

i_d (100%) =	25	A
Q_{rr} (100%) =	4,94	μC
t_{Qrr} =	0,90	μs

Figure 10 Output inverter FRED

Turn-on Switching Waveforms & definition of t_{Erec}
(t_{Erec} = integrating time for E_{rec})

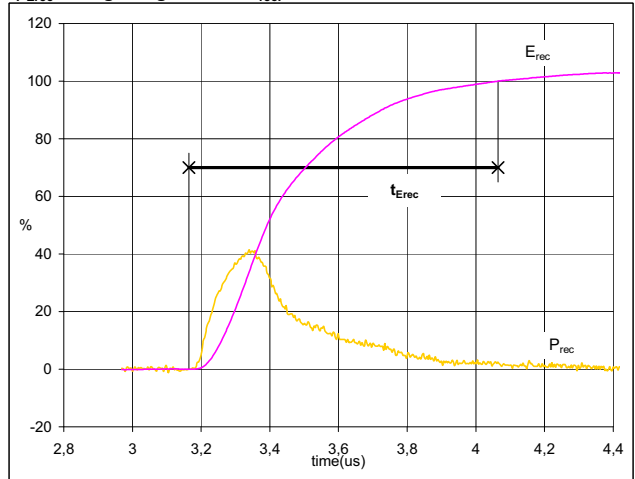

P_{rec} (100%) =	15,10	kW
E_{rec} (100%) =	1,97	mJ
t_{Erec} =	0,90	μs

Package Outline and Pinout

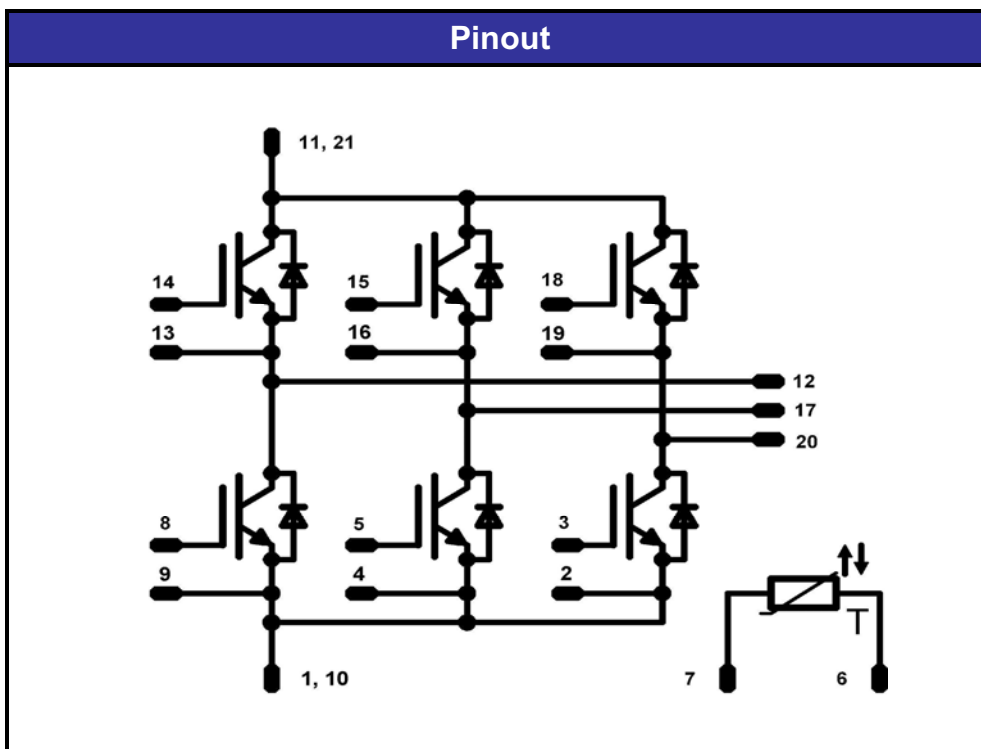
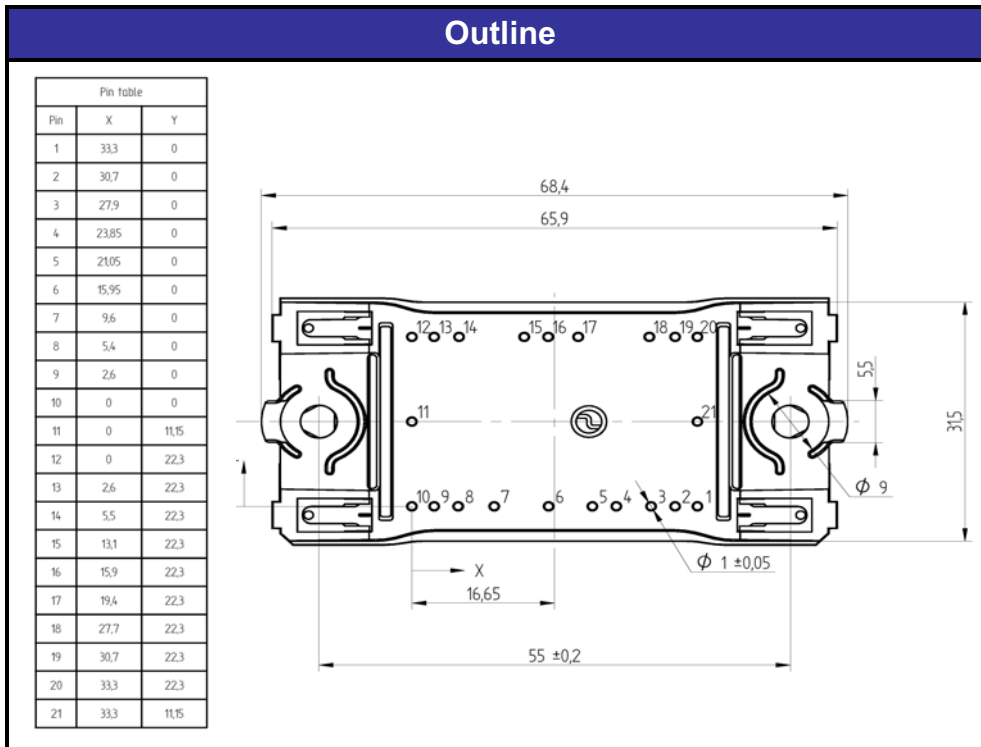

PRODUCT STATUS DEFINITIONS

Datasheet Status	Product Status	Definition
Target	Formative or In Design	This datasheet contains the design specifications for product development. Specifications may change in any manner without notice. The data contained is exclusively intended for technically trained staff.
Preliminary	First Production	This datasheet contains preliminary data, and supplementary data may be published at a later date. Vincotech reserves the right to make changes at any time without notice in order to improve design. The data contained is exclusively intended for technically trained staff.
Final	Full Production	This datasheet contains final specifications. Vincotech reserves the right to make changes at any time without notice in order to improve design. The data contained is exclusively intended for technically trained staff.

DISCLAIMER

The information given in this datasheet describes the type of component and does not represent assured characteristics. For tested values please contact Vincotech. Vincotech reserves the right to make changes without further notice to any products herein to improve reliability, function or design. Vincotech does not assume any liability arising out of the application or use of any product or circuit described herein; neither does it convey any license under its patent rights, nor the rights of others.

LIFE SUPPORT POLICY

Vincotech products are not authorised for use as critical components in life support devices or systems without the express written approval of Vincotech.

As used herein:

1. Life support devices or systems are devices or systems which, (a) are intended for surgical implant into the body, or (b) support or sustain life, or (c) whose failure to perform when properly used in accordance with instructions for use provided in labelling can be reasonably expected to result in significant injury to the user.
2. A critical component is any component of a life support device or system whose failure to perform can be reasonably expected to cause the failure of the life support device or system, or to affect its safety or effectiveness.